



PT2E-17319

Smart Transmitter/Gas Detector Head

SD-D58-AC

SD-D58-DC

(TYPE GP)

(TYPE NC)

(TYPE NCW)

(TYPE GP H)

(TYPE NC H)

Operating Manual

RIKEN KEIKI Co., Ltd.

2-7-6 Azusawa, Itabashi-ku, Tokyo, 174-8744, Japan

Phone : +81-3-3966-1113

Fax : +81-3-3558-9110

E-mail : intdept@rikenkeiki.co.jp

Web site : <https://www.rikenkeiki.co.jp/english/>

Operating Precautions

This detector head is a gas detector that detects combustible gases in the air and triggers a gas alarm. The gas detector is a safety unit, not an analyzer or densitometer which performs quantitative/qualitative analysis/measurement for gases.

Please fully understand the following points before using it, so that it can be used properly.

1. This detector head may be interfered by gases and vapors other than the gas to be detected. Please note that the alarm may be triggered by interference. In addition, it may be fluctuated by environmental (temperature, humidity, etc.) changes in the installation site.
2. The alarm must be set within a range where the performance of the detector head can be ensured. In facilities compliant with the High Pressure Gas Safety Act, an alarm setting below our standard alarm setpoint may trigger a false alarm.
3. This is a safety unit, not a control unit.
The alarm contact output of the detector head must be used for an external alarm lamp/buzzer, while the alarm signal output must be used for an indicator or external recorder.
If these outputs are used to control other units, we shall not be responsible for any malfunctions.
4. The gas sensing part of the gas sensor installed in this detector head is made of metal porous sintered alloy permeated with an oxidation catalyst.
If silicon or sulfide compounds are accumulated on the surface of porous sintered alloy, the area of the gas sensing part becomes smaller, which may results in serious deterioration of its sensitivity.
For safety reasons, do not use the detector head under the presence of silicon or sulfide compounds even though their amount is very small.
5. For maintenance of the detector head, it must go through a regular maintenance, including replacement and adjustment of the regular replacement parts as specified in the operating manual. In addition, because this is a safety unit, it is recommended that a regular maintenance and a gas calibration are performed every six months in accordance with the regulations.

<Contents>

1.	Outline of the Product.....	4
1-1.	Preface.....	4
1-2.	Purpose of use.....	4
1-3.	Definition of DANGER, WARNING, CAUTION, and NOTE.....	5
1-4.	Method of confirmation for Standards and Explosion proof specification.....	5
2.	Important Notices on Safety.....	6
2-1.	Danger cases.....	6
2-2.	Warning cases.....	7
2-3.	Precautions.....	8
2-4.	Safety Information.....	9
3.	Product Components.....	14
3-1.	Main unit and standard accessories.....	14
3-2.	Names and functions for each part.....	16
3-3.	Block diagram.....	21
4.	How to Use.....	23
4-1.	Before using the detector head.....	23
4-2.	Precautions for installation points.....	23
4-3.	Precautions for system designing.....	24
4-4.	How to install.....	27
4-5.	How to wire.....	29
4-6.	How to tube.....	37
5.	How to Operate.....	38
5-1.	Preparation for start-up.....	38
5-2.	Basic operating procedures.....	39
5-3.	How to start the detector head.....	40
5-4.	Modes.....	40
5-5.	Maintenance mode (User).....	42
5-6.	How to exit.....	45
6.	Operations and Functions.....	46
6-1.	Gas alarm activation.....	46
6-2.	Fault alarm activation.....	47
6-3.	Low Flow Rate Abnormal Operations.....	47
6-4.	External output operation.....	48
6-5.	Other functions.....	50
7.	Maintenance.....	51
7-1.	Maintenance intervals and items.....	51
7-2.	Maintenance mode (Regular maintenance).....	53
7-3.	Gas calibration method.....	61
7-4.	How to maintain flow sensor.....	68
7-5.	Parts replacement.....	69
8.	Storage, Relocation and Disposal.....	71
8-1.	Procedures to store the detector head or leave it for a long time.....	71
8-2.	Procedures to relocate the detector head or use it again.....	71
8-3.	Product disposal.....	71
9.	Troubleshooting.....	72
10.	Product Specifications.....	74
10-1.	List of specifications.....	74
10-2.	Detection principle.....	96
11.	Definition of Terms.....	98

1

Outline of the Product

1-1. Preface

Thank you for choosing our smart transmitter/gas detector head SD-D58 series. Please check that the model number of the product you purchased is included in the specifications on this manual.

This manual explains how to use the detector head and its specifications. It contains information required for using the detector head properly. Not only the first-time users but also the users who have already used the product must read and understand the operating manual to enhance the knowledge and experience before using the detector head.

The detector head has five types of TYPE GP/TYPE NC/TYPE NCW and HART communication TYPE GP H/TYPE NC H. In this manual, instructions of TYPE GP (such as an example of LED display) are described as example.



1-2. Purpose of use

- The detector head is a fixed type detector head that detects leak of combustible gases and that performs the alarm activation when the gas concentration is over the setting value. The detector head is a safety unit, not an analyzer or densitometer which performs quantitative/qualitative analysis/measurement for gases. Please fully understand the features of the detector head before using it, so that it can be used properly.
- The detector head draws air with the built-in pump, and detects abnormalities in the air caused by presence of gases or other reasons (leak) with the built-in gas sensor. The concentrations of detected gases are displayed on the seven-segment LED.
- The detector head has a built-in alarm contact and can be used either as a gas alarm, fault alarm, or common (gas, fault) alarm.
- The detector head has a built-in low flow rate detection function and can trigger a fault alarm when the flow rate inside the tubing drops below a fixed rate.
- The detector head outputs gas concentration in 4 – 20 mA.
- SD-D58 series have two types of power supply specifications.

SD-D58·AC	AC power specification 100 – 110VAC
SD-D58·DC	DC power specification 24VDC

- TYPE GP H/TYPE NC H have HART communication function.

1-3. Definition of DANGER, WARNING, CAUTION, and NOTE

 DANGER	This message indicates that improper handling may cause death or serious damage on health or assets.
 WARNING	This message indicates that improper handling may cause serious damage on health or assets.
 CAUTION	This message indicates that improper handling may cause minor damage on health or assets.
NOTE	This message indicates advice on handling.

1-4. Method of confirmation for Standards and Explosion proof specification

The product specifications will vary depending on the specific standards and explosion-proof certification. Check the actual product specifications before use. You can confirm instrument specification to see name plate as follows.



ATEX, CE marking type name plate
(DC power specification only)

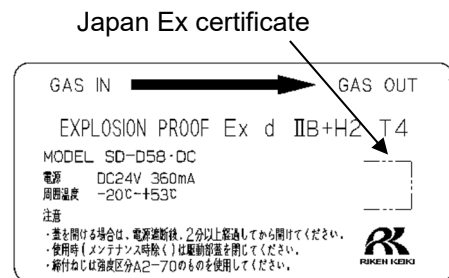

Japan Ex type name plate
(AC/DC power specification)

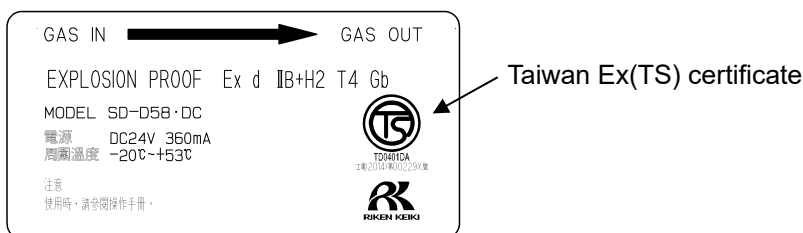

Taiwan Ex(TS) type name plate
(AC/DC power specification)

2

Important Notices on Safety

2-1. Danger cases



DANGER

<About explosion-proof>

- The window plate material is a polycarbonate resin. Do not use organic solvents and alkali types (liquid or vapor). It may cause the color and shape of the window plate to be changed.
- The flameproof joints are not intended to be repaired.
- Do not open the lid when applying current. The lid may be opened after five minutes or more after power off.
- Do not attempt to repair the detector head by the user.
- For the lid, use hexagon socket head bolts specified by RIKEN KEIKI.
- The drive lid must be closed during use (except during maintenance).
- Chloroprene rubber (CR) is used for the components of the cable gland. The explosion-proof performance may not be maintained depending on the organic solvent / alkali (liquid or vapor) present in the measurement environment.
- Do not repair or replace the explosion-proof contact surfaces. If scratches, cracks, deformation etc. are seen on the container or explosion-proof joint surface, please stop using it immediately and promptly contact the dealer or our nearest sales office.
- The pump unit is replaced once every two years.

2-2. Warning cases



WARNING

Power supply

Before turning on the detector head, always check that the voltage is properly applied. Do not use an unstable power supply because it may cause malfunctions.

Need of grounding circuit

Do not cut the grounding circuit or disconnect the wire from the grounding terminal.

Defects in protective functions

Before starting the detector head, check the protective functions for defects. When seeming defects are found in the protective functions, such as protective grounding, do not start the detector head.

External connection

Before connecting the detector head to the external control circuit, securely connect it to a protective grounding circuit.

Zero adjustment in the atmosphere

When the zero adjustment is performed in the atmosphere, check the atmosphere for freshness before beginning the adjustment. If other gases exist, the adjustment cannot be performed properly, thus leading to dangers when the gas leaks.

Response to gas alarm

Issuance of a gas alarm indicates that there are extreme dangers. Take proper actions based on your judgment.

Do not use the low flow rate alarm function under the presence of silicon.

Silicon may accumulate on the sensing part of the flow sensor, which can result in malfunction.

Do not use the low flow rate alarm function under the presence of corrosive gas

Corrosive gas (chlorine, sulfur, acid, alkaline, halogen) may corrode the flow sensor, which can result in malfunction.

Do not use the low flow rate alarm function under the presence of high-concentrated gas

Under the presence of high-concentrated combustible gas over the lower explosive limit, the flow sensor may be overheated, which can result in malfunction.

2-3. Precautions



CAUTION

Do not use a transceiver or such a device near the detector head.

Radio wave from a transceiver near the detector head or its cables may disturb indication reading. If a transceiver is used, it must be used in a place where it disturbs nothing.

To restart the detector head, wait for five seconds or more before doing it.

Restarting the detector head within five seconds may cause errors.

Do not use the external output of the detector head to control other units.

This is not a control unit. It is not allowed to use the external output of the detector head to control other units.

Do not disassemble/modify the detector head, or change the settings if not necessary.

Disassembling/modifying the detector head will invalidate the warranty of the performance. Changing the settings without understanding the specifications may cause alarm malfunctions. Please use the detector head properly in accordance with the operating manual.

Avoid applying organic solvents and others to the window plate for a long time.

The window plate material is a polycarbonate resin. When organic solvents (liquid or highly-concentrated vapor) and others are applied to the plate for a long time, its color and shape may be changed.

Never fail to perform a regular maintenance.

Since this is a safety unit, a regular maintenance must be performed to ensure safety. Continuing to use the detector head without performing a maintenance will deteriorate the sensitivity of the sensor, thus resulting in inaccurate gas detection.

Use the low flow rate alarm function only under the atmosphere of air or nitrogen.

The flow sensor measures the change of radiation amount caused by air current. Different air type has a different radiation characteristic, which can result in malfunction. For the following gas types and concentrations, the low flow rate warning function can not be used. Example) argon, helium, and hydrogen > 5 vol %, carbon dioxide, propane, ethane > 50 vol %, methane > 25 vol %

When using the low flow rate alarm function, use any filter depending on the operating environment.

Otherwise dust and/or mist can cause clogging on the flow sensor, which can result in malfunction. Set a dust filter and/or mist separator on the upstream side of tubing depending on the operating environment.

2-4. Safety Information

Necessary information for explosion proof construction of Model SD-D58·AC/SD-D58·DC.

The Model SD-D58·AC/SD-D58·DC is a fixed mount, continuous-monitoring detector head and provides a 4-20mA signal which indicates the target gas reading for use by a gas monitoring controller, recording device, or programmable controller.

There is one point of contact and works by gas warning or trouble or both by setting.

<ATEX Specifications>

Technical Data

(Protection Method)	Flameproof enclosure “d”
(Group)	II
(Category)	2 G
(Type of Protection and Marking code)	Ex db h II B+H2 T4
(Equipment Protection Level)	Gb
(Ambient Temperature)	-20°C to +53°C
(Type designation)	

*	—	D58	.	DC	.	*
1		2		3		4

Ref.	Prefix	Description details
1	GD	Gas detector
	SD	Smart detector
	RP	Pump
2	D58	Constant number
3	DC	Direct current power supply
4	Blank	Catalytic Combustion Method(GD,SD)
	Blank	None(RP)
	GH	Semi-Conductor Method

(Electrical Data)

Model	Power supply	Signal output	Contact output	Gas sensor power supply	Flow sensor power supply
SD-D58 · DC	DC24V 360mA	① (4-20mA) DC24V、max.22mA ② (4-20mA) DC24V、max.22mA with HART	DC30V/AC250 V、 0.5A	DC5.0V 200mA or DC3.0V 430mA	DC2.0V 170mA
GD-D58 · DC	DC24V 360mA	(Gas Sensor) DC5.0V 200mA or DC3.0V 430mA	—	DC5.0V 200mA or DC3.0V 430mA	DC2.0V 170mA
SD-D58 · DC · GH	DC24V 360mA	① (4-20mA) DC24V、max.22mA ② (4-20mA) DC24V、max.22mA with HART	DC30V/AC250 V、 0.5A	DC6.5V 205mA or DC3.5V 350mA	DC2.0V 170mA
GD-D58 · DC · GH	DC24V 360mA	(Gas Sensor) DC6.5V 205mA or DC3.5V 350mA	—	DC6.5V 205mA or DC3.5V 350mA	DC2.0V 170mA
RP-D58 · DC	DC24V 360mA	—	DC30V/AC250 V、 0.5A	—	DC2.0V 170mA

(Certificate numbers)

DEKRA 24 ATEX 0036X

(Applicable Standard)

EN IEC 60079-0 : 2018, EN 60079-1: 2014

Specific conditions of “X”-mark:

- Fasteners from stainless steel property class A2-70 are used. The fasteners shall only be replaced with identical ones.
- The flameproof joints not intended to be repaired.
- The unearthed conductive [label] has a capacitance of 15 nF. Suitability in the specific application shall be determined by the user.

Installation

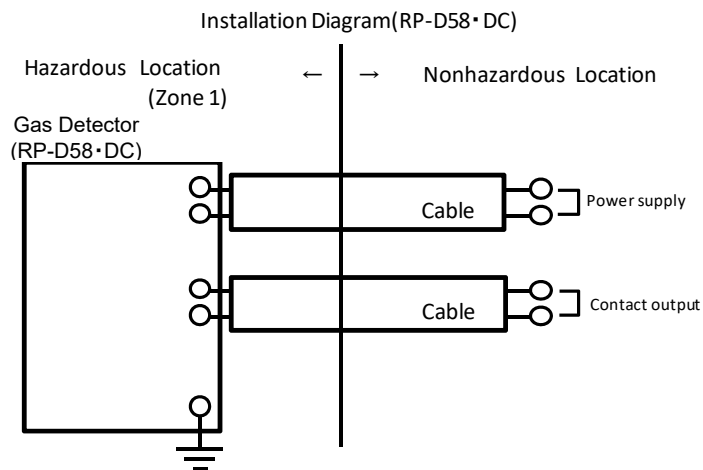
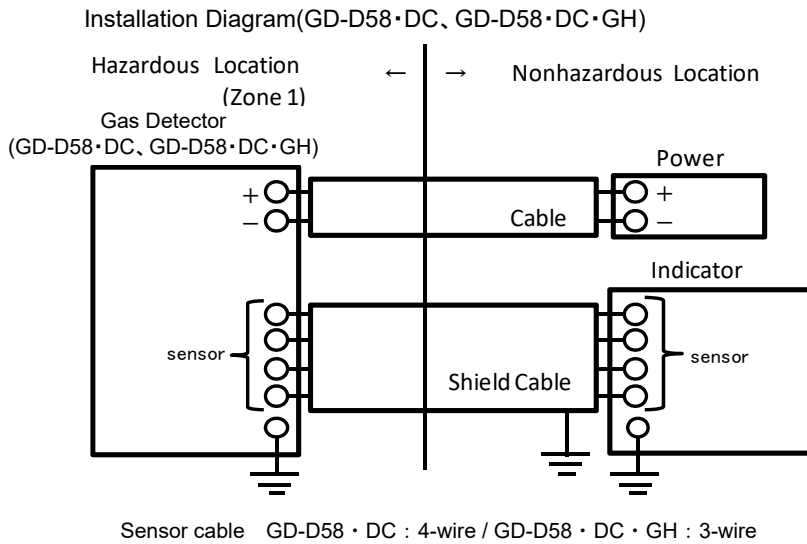
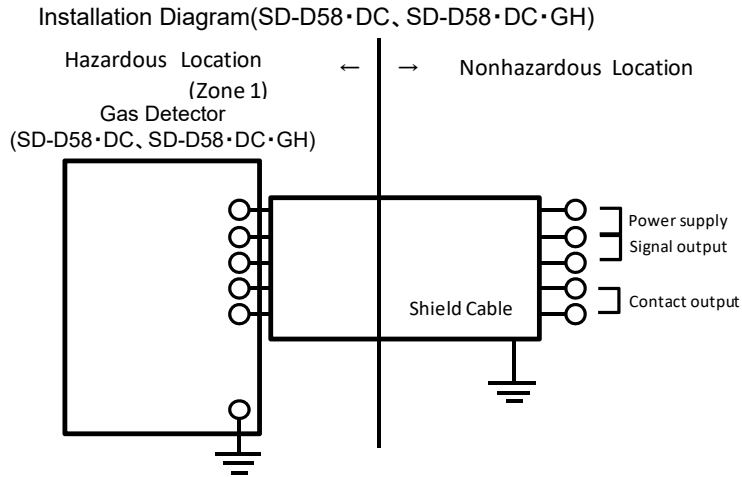

Caution

- Please follow the installation requirement about the installation.
- Please do not open the cover while working.
- When you open cover, please go after two minutes or more after power supply cutting.
- Excessively, please setting do not resolve, do not remodel, and do not change this container.
- The re-adjustment and parts replacement etc including the gas calibration shall be contacted to our nearest agent or RIKEN KEIKI.
- If any abnormality is found, please contact our nearest agent or RIKEN KEIKI at your earliest.
- Please do a regular check.
- For electrical connection suitable cable shall be used.
- Please be attached to electrical connection without the slack and torsion using a cable rag safely.
- The flameproof joints are not intended to be repaired.
- The bolt with the hexagon socket must use the stainless steel material of property class "A2-70".
- This product must be used in a fixed.
- The window plate material is a polycarbonate resin. Do not use organic solvents and alkali type.
- CR is used in the construction of the Cable glands, its performance should be considered with respect to the chemicals that may be present in the hazardous area.
- The pump unit is replaced once every two years.

<Taiwan Ex(TS) Specifications>

Technical Data

(Protection Method)	Flameproof enclosure
(Explosion-proof class)	Ex d II B+H2 T4 Gb
(Ambient Temperature)	Type AC: -20°C to +50°C Type DC: -20°C to +53°C
(Electrical Data)	
Supply voltage :	Type AC: AC100-110V 50/60Hz 120mA Type DC: DC24V 360mA
Electrical rating :	DC3.0V 430mA or DC5.0V 200mA
Flow rate element power output :	DC2.0V 170mA
Analog signal output :	DC24V 25mA
Contact output :	AC250V 0.5A(Load resistance) DC30V 0.5A(Load resistance)
(Applicable Standard)	JNIOSH-TR-NO. 43(2008)

Installation

【SD-D58·AC】

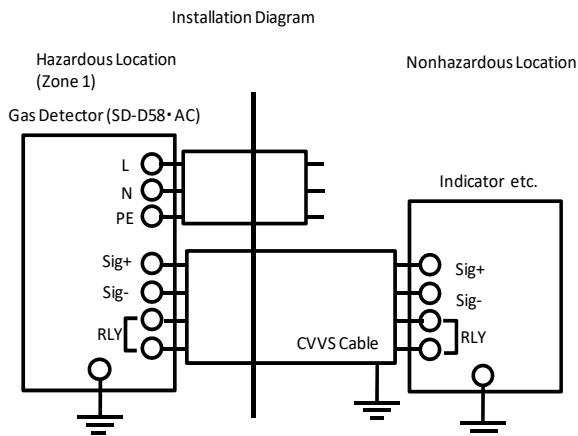

【SD-D58·DC】

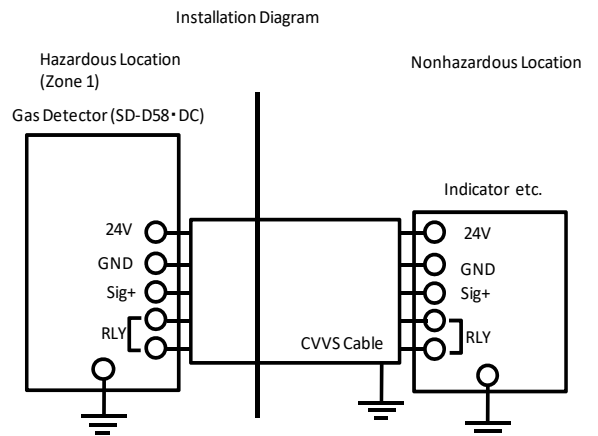

<Japan Ex Specifications>

Technical Data

(Protection Method)	Flameproof enclosure
(Explosion-proof class)	Ex d II B+H2 T4
(Ambient Temperature)	Type AC: -20°C to +50°C Type DC: -20°C to +53°C
(Electrical Data)	
Supply voltage :	Type AC: AC100-110V 50/60Hz 120mA Type DC: DC24V 360mA
Electrical rating :	DC3.0V 430mA or DC5.0V 200mA
Flow rate element power output :	DC2.0V 170mA
Analog signal output :	DC24V 25mA
Contact output :	AC250V 0.5A(Load resistance) DC30V 0.5A(Load resistance)
(Applicable Standard)	JNIOSH-TR-NO. 43(2008)

Installation

【SD-D58·AC】

【SD-D58·DC】

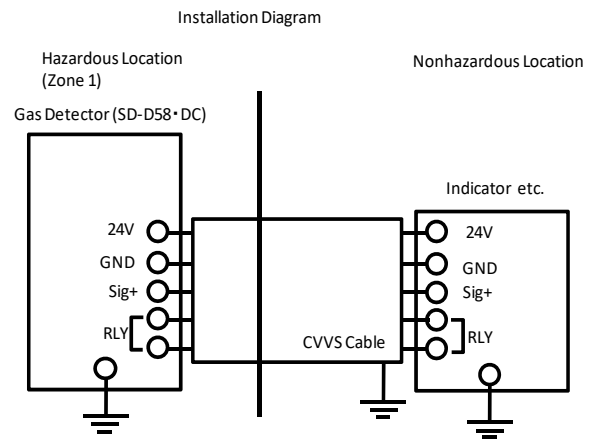
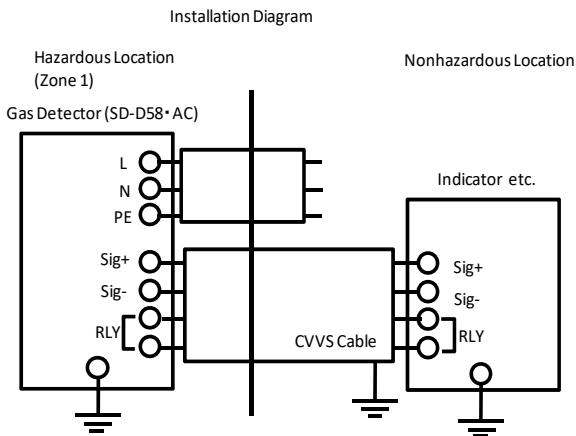

3

Product Components

3-1. Main unit and standard accessories

<Main Unit> (including cable glands)

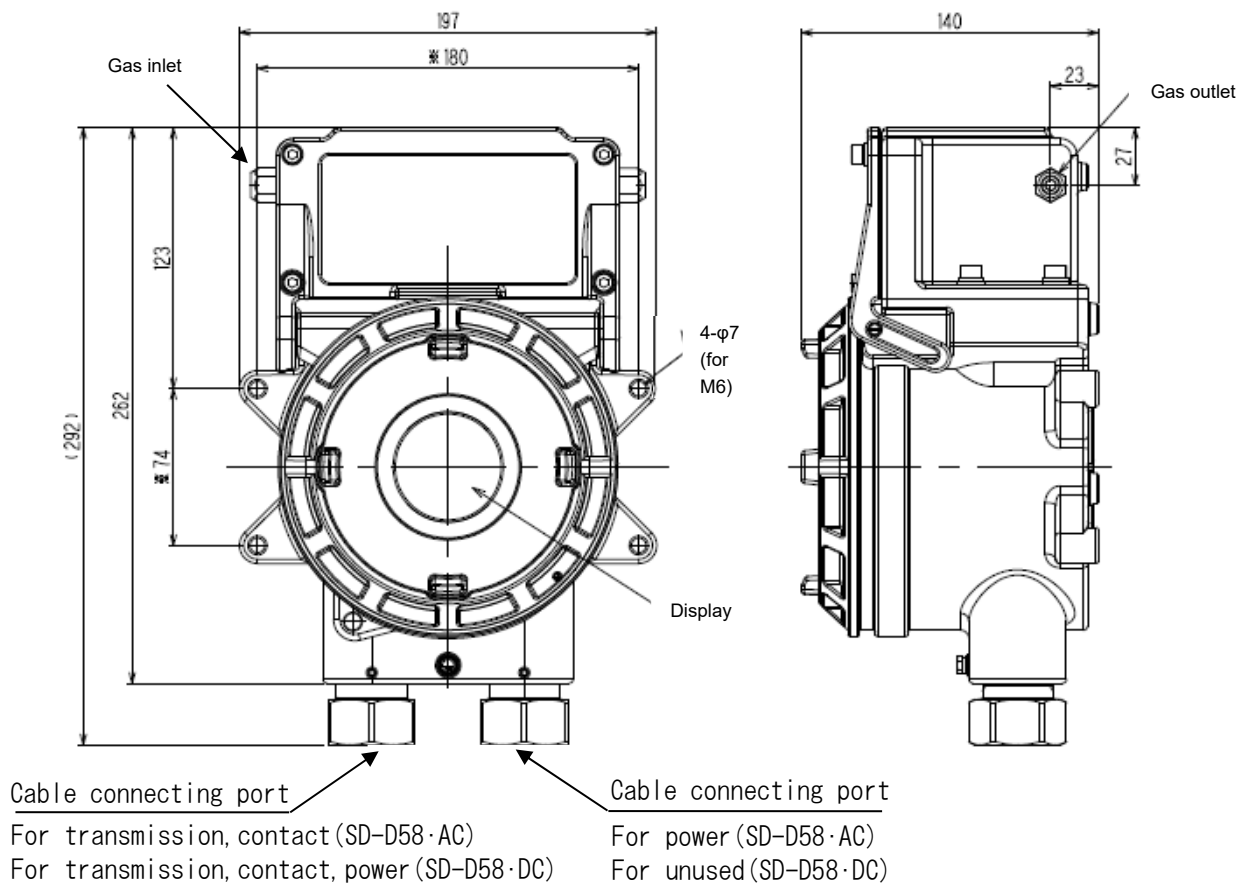

Unit: mm

<Standard Accessories>

- Operating manual
- Dedicated handling lever 1 lever
- Dedicated control key The control key quantity depends on the number of detector heads to be delivered.

1 to 10 units	1 key
11 - 20 units	2 keys
21 - 50 units	3 keys
Over 51 units	4 keys

- Hex key wrench Same number of wrenches as with the test certificates will be provided.
- Dust removal filter with flow monitor... 1 filter



CAUTION

- Use the supplied dedicated control key to operate the detector head. If products other than these accessories are used, key operations cannot be accepted properly.
- The control key is made of an extremely strong magnet. Keep it away from a credit card, ID card, or other magnetic product because stored data may be destroyed.

3-2. Names and functions for each part

<Display>

In cases other than TYPE NCW

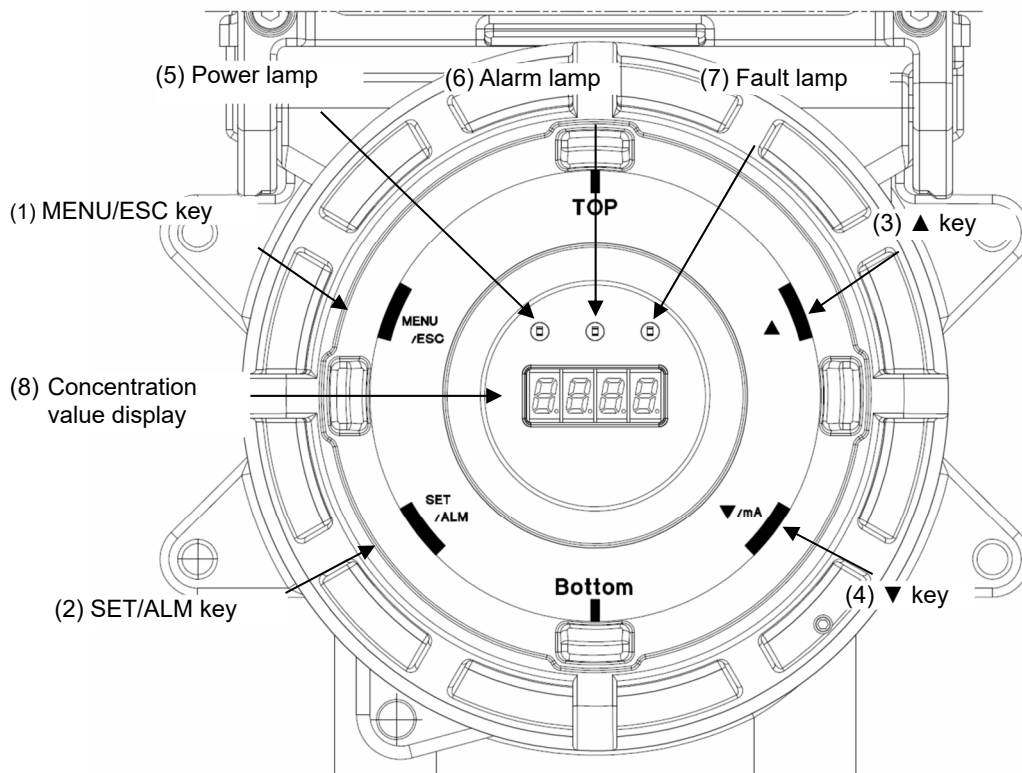

(1)	MENU/ESC key	Used to enter the maintenance mode. It is also used to cancel in a specific mode.
(2)	SET/ALM key	It is used for value confirmation and so on in a specific mode.
(3)	▲ key	Used to switch menus or change a value (UP).
(4)	▼ key	Used to switch menus or change a value (DOWN).
(5)	Power lamp	Power lamp. Detection mode: It lights up in green. Maintenance mode: It blinks in green.
(6)	Alarm lamp	Alarm lamp. It lights up in red when the alarm setpoint value is reached.
(7)	Fault lamp	Fault lamp. It lights up in yellow when an abnormality is detected in the detector head.
(8)	Concentration value display	Displays the gas concentration and so on.

NOTE

The nameplate on the front side of the detector head shows the precautions to be taken for explosion-proof performances. Read these precautions as well as "2. Important Notices on Safety."

In cases TYPE NCW

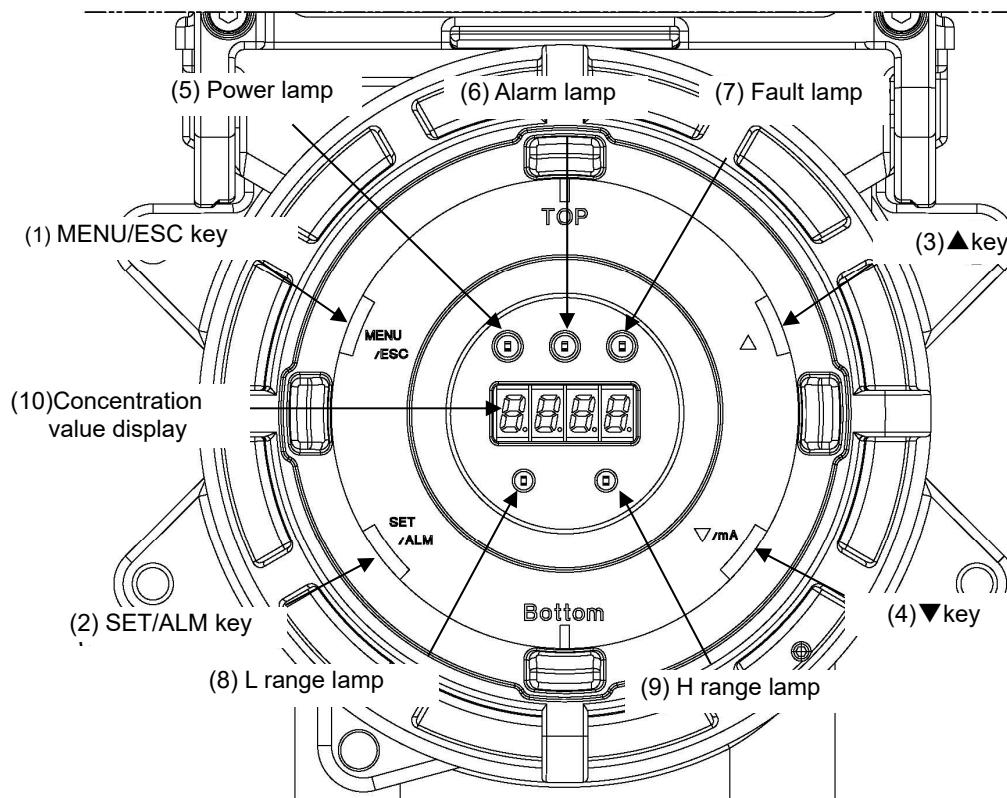

(1)	MENU/ESC key	Used to enter the maintenance mode. It is also used to cancel in a specific mode.
(2)	SET/ALM key	It is used for value confirmation and so on in a specific mode.
(3)	▲ key	Used to switch menus or change a value (UP).
(4)	▼ key	Used to switch menus or change a value (DOWN).
(5)	Power lamp	Power lamp. Detection mode: It lights up in green. Maintenance mode: It blinks in green.
(6)	Alarm lamp	Alarm lamp. It lights up in red when the alarm setpoint value is reached.
(7)	Fault lamp	Fault lamp. It lights up in yellow when an abnormality is detected in the detector head.
(8)	L range lamp	It is an L range lamp. It lights when gas concentration is within the range of L range.
(9)	H range lamp	It is an H range lamp. It lights when gas concentration is within the range of L range.
(10)	Concentration value display	Displays the gas concentration and so on.

<Inside of the main unit> (Electric circuit section)

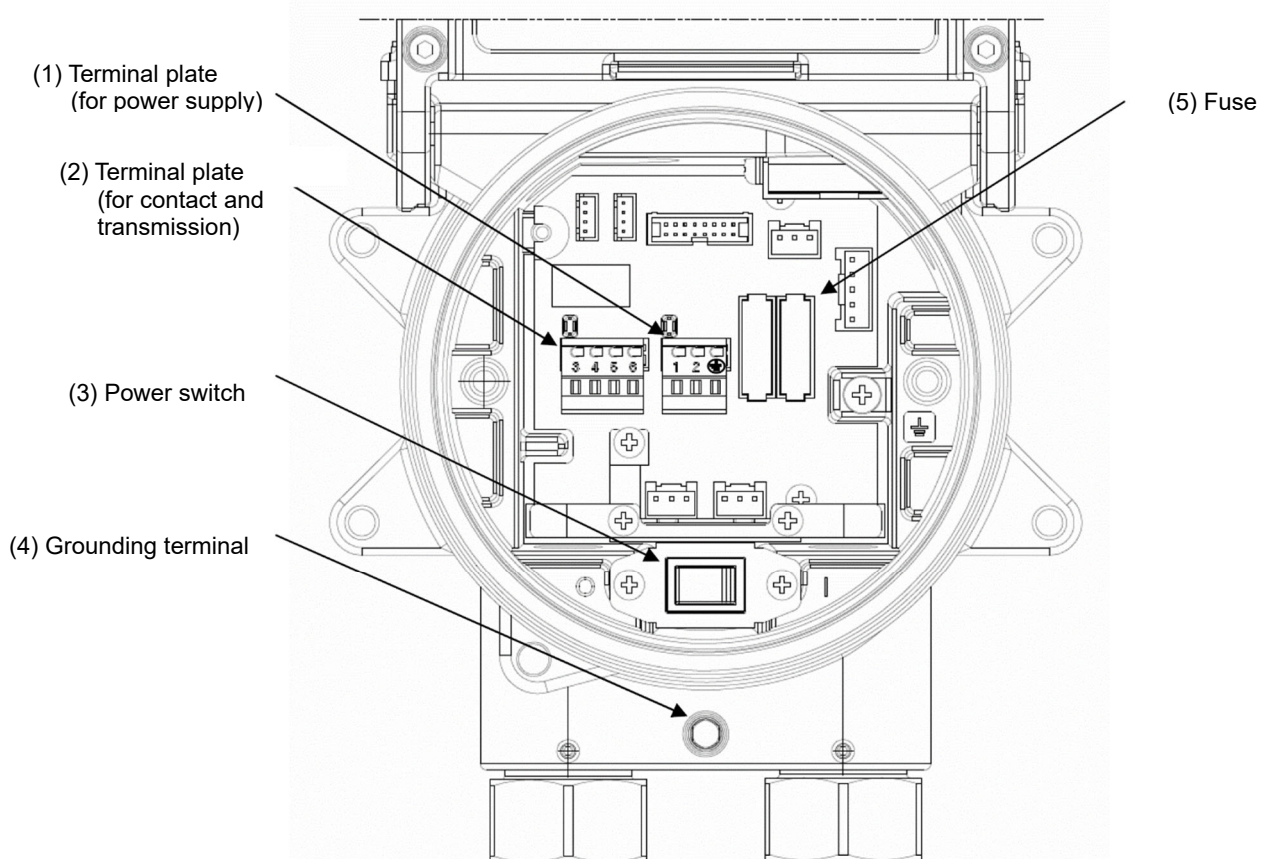

(1)	Terminal plate (for power supply)	Power input terminal plate. *1 *2
(2)	Terminal plate (for contact and transmission)	Signal (contact and gas concentration) output terminal plate. *3
(3)	Power switch	Power switch of the detector head. *1
(4)	Grounding terminal	Terminal for grounding. (M4×6)
(5)	Fuse	Main power fuse. *1

*1 Only SD-D58·AC/SD-D58·AC(TYPE H).

*2 The power input terminal plate of SD-D58DC/SD-D58·DC(TYPE H) are as common as terminal plate for contact and transmission output. See "4-5. How to wire <Figure of Terminal Plate>" for details.

*3 SD-D58·DC/SD-D58·DC(TYPE H) are the power input and terminal plate for contact and transmission output. See "4-5. How to wire <Figure of Terminal Plate>" for details.

NOTE

Open the electric circuit lid.

Remove the electric circuit lid and display unit to find behind them the electric circuit section shown in the figure above.

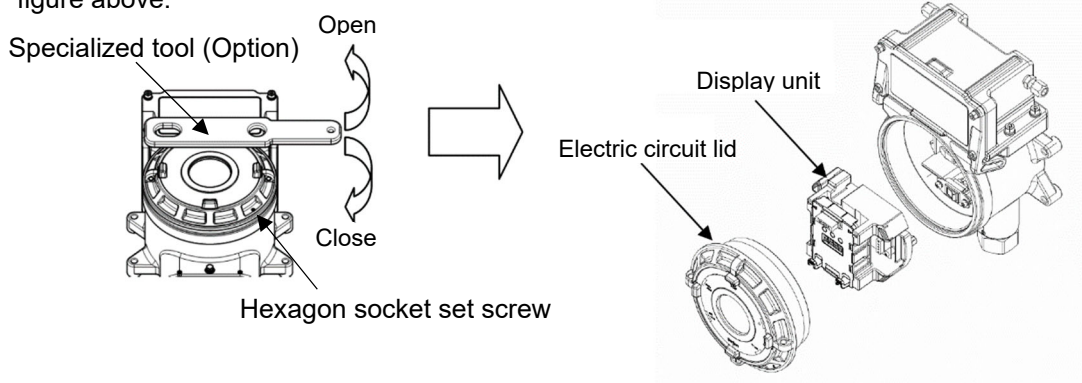

- Power input terminal plates are SD-D58·AC: 3-pole and SD-D58·DC: 2-pole.
- After use, closely tighten the lid until the thread is no longer seen (clockwise 8 rotations +1/4 rotation or more) and the "TOP" marking faces upward. Tighten the hexagon socket set screw with a tightening torque of 107.8±12.7 N·cm.

<Inside of the main unit> (Drive section)

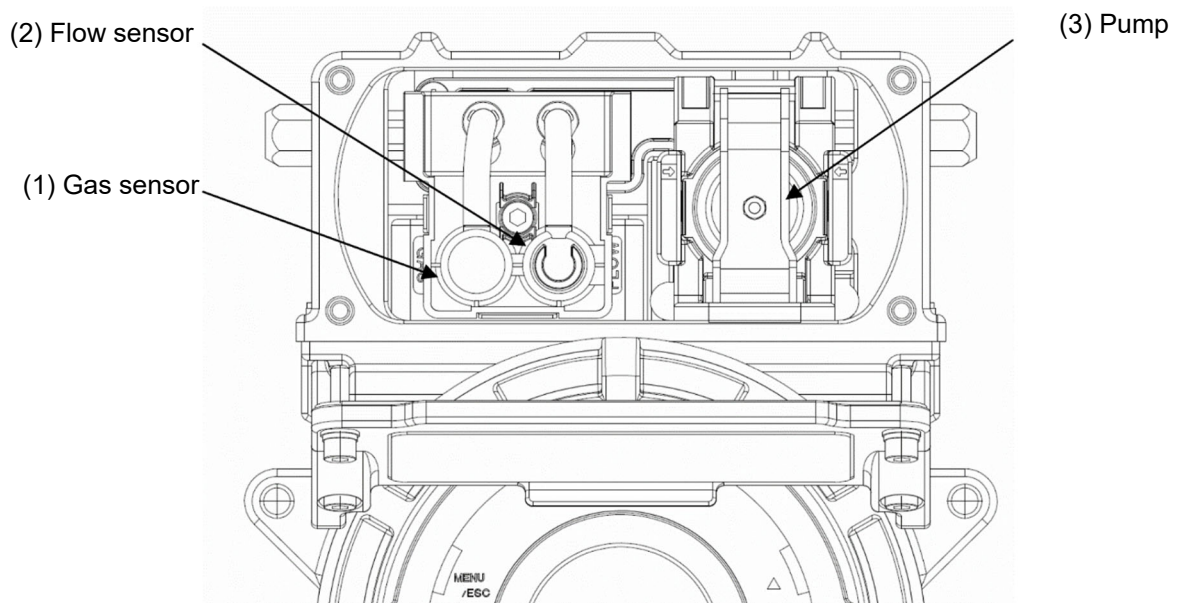

(1)	Gas sensor	Gas detection sensor.
(2)	Flow sensor	Sensor for detection of low flow rate.
(3)	Pump	Sample draw pump.

NOTE

Open the drive lid and the hexagon socket head bolts on the four corners.

Remove the drive lid to find the drive section shown in the figure above.

The bolt with the hexagon socket must use the stainless steel material of property class "A2-70".

- Grease specified by RIKEN KEIKI : BARRIERTA JFE 552 (manufactured by NOK KLUBER)

If you can not prepare the specified grease, use one that meets the following requirements.

1. Material does not harden due to deterioration
2. Volatile solvent-free
3. Material does not cause corrosion at the surface
4. Silicon-free
5. Validation of suitability depends on the specifications of grease manufacturer

Drive lid

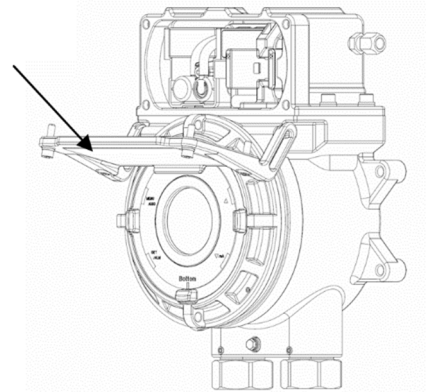

3-3. Block diagram

<Electric Diagram>

SD-D58·AC

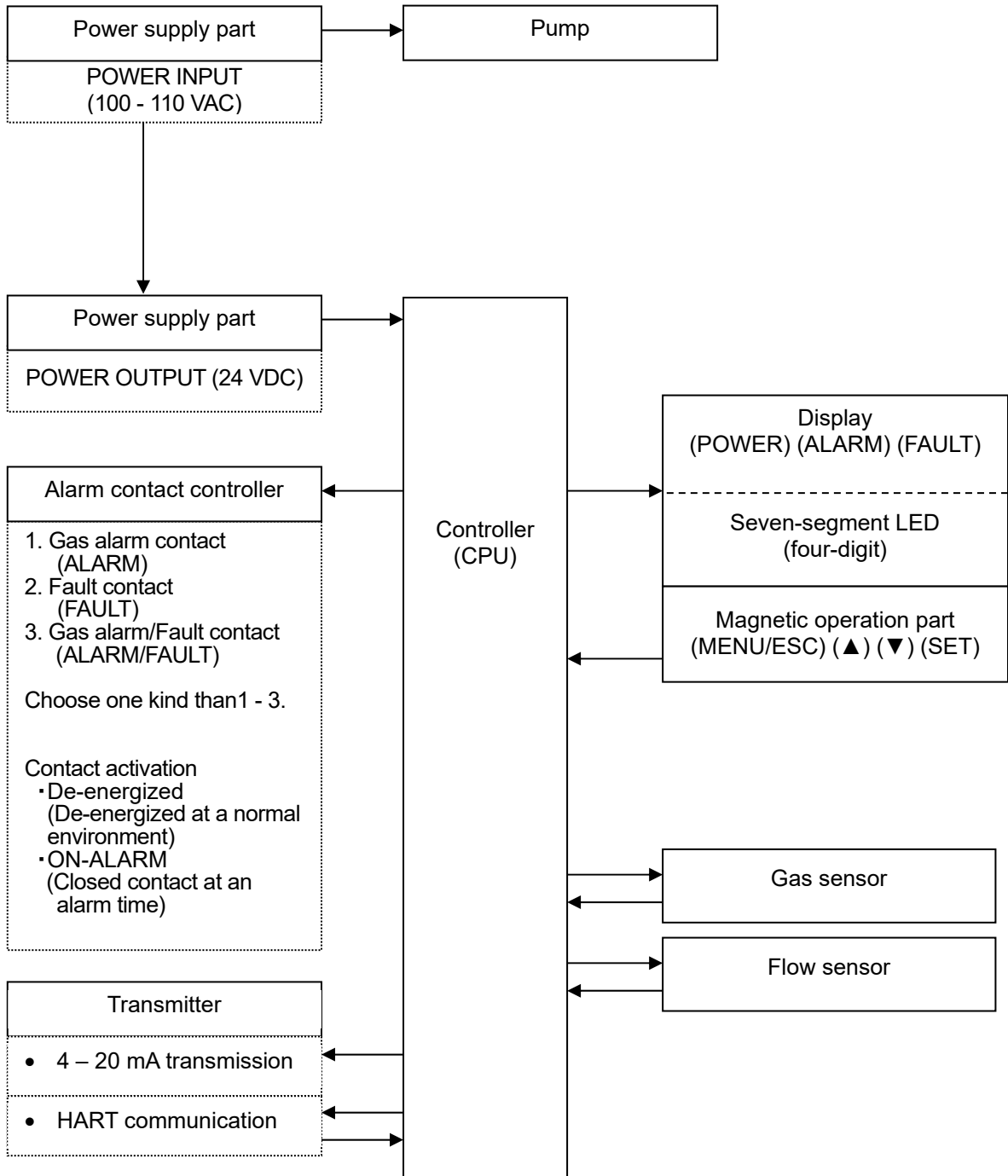

<Electric Diagram>

SD-D58·DC

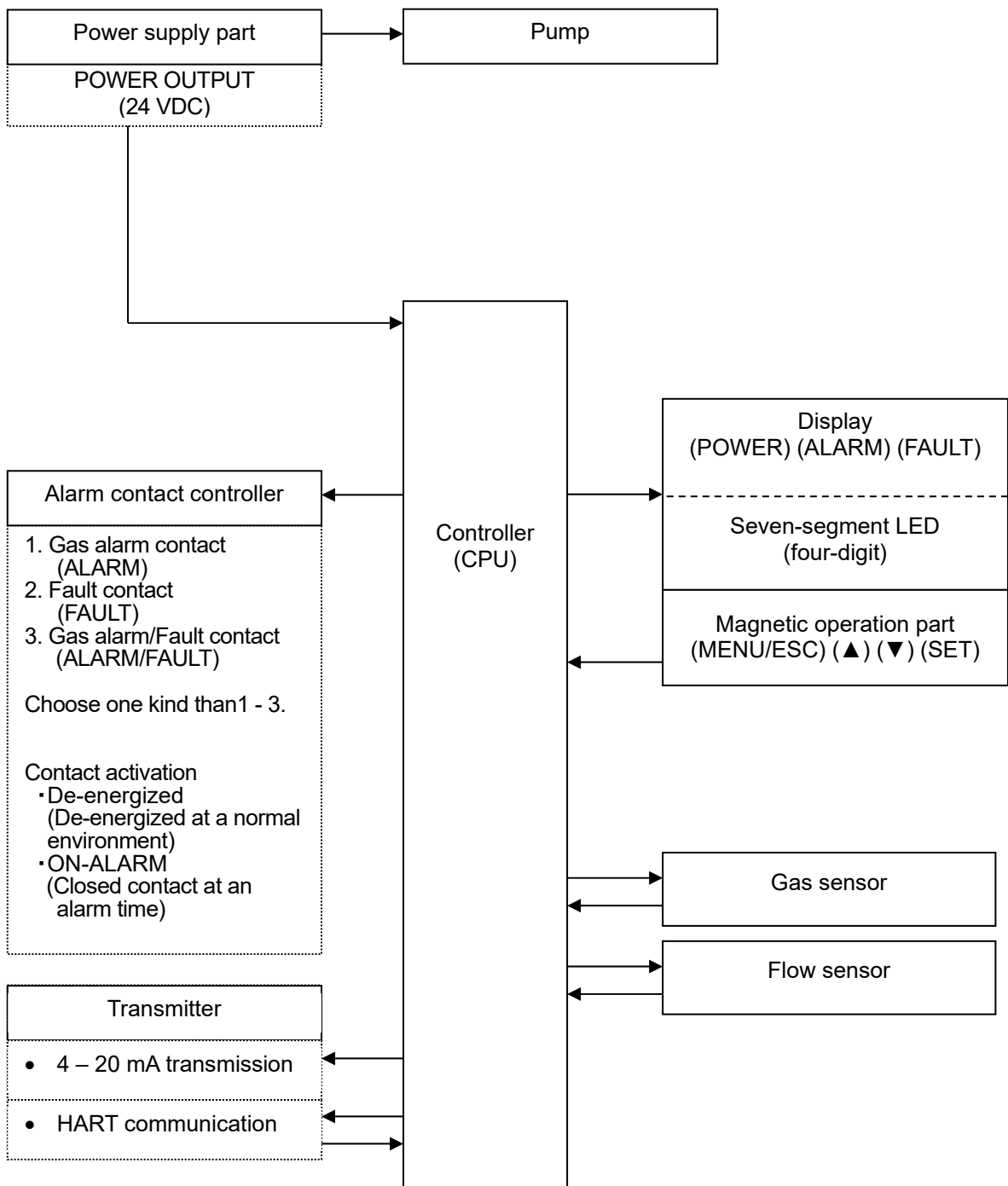

4

How to Use

4-1. Before using the detector head

Not only the first-time users but also the users who have already used the product must follow the operating precautions.

Ignoring the precautions may damage the detector head, resulting in inaccurate gas detection.

4-2. Precautions for installation points



CAUTION

- This detector head is a precision device. Because the detector head may not provide the specified performance in some places (environments), check the environment in the installation point, and then take appropriate actions if necessary.
- Because the detector head plays an important role for safety and disaster prevention, as many units of the detector head needed must be installed in appropriate points. Because points where gases leak and remain easily are different depending on the types of gases and the working areas, please decide carefully on installation points and the number of units to be installed.

Do not install the detector head in a place with vibrations or shocks.

The detector head consists of sensitive electronic parts. The detector head must be installed in a stable place without vibrations or shocks and it cannot drop.

Do not install the detector head in a place exposed to water, oil or chemicals.

When selecting installation points, avoid a place where the detector head is exposed to water, oil or chemicals.

Do not install the detector head in a place where the range of operating temperatures is exceeded.

The detector head must be installed in a stable place where the operating temperature is maintained and do not change suddenly.

<ATEX Specifications> SD-D58·DC : -20°C- +53°C

<Taiwan Ex(TS) Specifications> SD-D58·AC : -20°C- +50°C / SD-D58·DC : -20°C- +53°C

<Japan Ex Specifications> SD-D58·AC : -20°C- +50°C / SD-D58·DC : -20°C- +53°C

Do not install the detector head in a place exposed to direct sunlight or sudden changes in the temperature.

When selecting installation points, avoid a place where it is exposed to direct sunlight or radiant heat (infrared rays emitted from a high-temperature object), and where the temperature changes suddenly. Condensation may be formed inside the detector head, or the detector head cannot adjust to sudden changes in the temperature.

Keep the detector head (and its cables) away from noise source devices.

When selecting installation points, avoid a place where high-frequency/high-voltage devices exist.

Do not install the detector head in a place where maintenance of the detector head cannot be performed or where handling the detector head involves dangers.

Regular maintenance of the detector head must be performed.

Do not install the detector head in a place where the machinery must be stopped when maintenance is performed in its inside, where parts of the machinery must be removed to perform maintenance, or where the detector head cannot be removed because tubes or racks prevent access to it. Do not install the detector head in a place where maintenance involves dangers, for example, near a high-voltage cable.

Do not install the detector head in machinery which is not properly grounded.

Before installing the detector head in machinery, the machinery must be grounded properly.

Do not install the detector head in a place where other gases exist around it.

The detector head must not be installed in a place where other gases exist around it.

4-3. Precautions for system designing



CAUTION

An unstable power supply and noise may cause malfunctions or false alarms.

The descriptions in this section must be reflected on the designing of a system using the detector head.

Using a stable power supply

The external output and alarm contact of the detector head may be activated when the power is turned on, when momentary blackout occurs, or while the system is being stabilized. In such cases, use a UPS (uninterrupted power supply), or take appropriate actions on the receiving side of output signals. The detector head must be provided with the following power supply.

Power supply voltage	SD-D58·AC:100 - 110 VAC ±10%, 50/60Hz : Terminal voltage of the detector head SD-D58·DC:24 VAC(DC21.6- 26.4V) : Terminal voltage of the detector head	
Allowed time of momentary blackout	SD-D58·AC: Less than approx. 200 msec (To recover from the momentary blackout for 200 milliseconds or more, restart the detector head.) SD-D58·DC: Less than approx. 10 msec (To recover from the momentary blackout for 10 milliseconds or more, restart the detector head.)	<u>Example of actions</u> To ensure continuous operation and activation, install a UPS outside the detector head.
Others	Do not use it with a power supply of large power load or high-frequency noise.	<u>Example of actions</u> Use a line filter to avoid the noise source if necessary.

Introducing protective measures against lightning

If cables are installed outside the factory/plant, or if internal cables are installed in the same duct as the cables coming from outside the factory/plant, "lightning" will cause problems. Because lightning acts as a large emission source while cables act as a receiving antenna, devices connected to the cables may be damaged.

Lightning cannot be prevented. Cables installed in a metal conduit or under the ground cannot be completely protected from inductive lightning surge caused by lightning. Although complete elimination of disasters caused by lightning is impossible, the following protective measures can be taken.

Protection against lightning	<p><u>Take appropriate measures in accordance with the importance of the facilities and the environment.</u></p> <ul style="list-style-type: none"> • Provide protection by a lightning arrester (cable arrester). (Although inductive lightning surge can be transmitted through the cable, it is prevented by installing a lightning arrester before the field devices and central processing equipment. For information on how to use a lightning arrester, please contact the manufacturer.)
Grounding	In addition to lightning, there are more sources of surge noise. To protect units from these noise sources, the units must be grounded.

* The lightning arrester has a circuit to remove a surge voltage which damages field devices, so that signals may be attenuated. Before installing a lightning arrester, verify that it works properly.

Proper use of alarm contact

The alarm contact of the detector head is used to transmit signals to activate an external buzzer, an alarm lamp or a rotating lamp. Do not use the detector head for controlling purpose (e.g., controlling the shutdown valve.)

The specifications for the alarm contact of the detector head are based on the resistant load conditions. If inductive load is used at the alarm contact, the following errors will occur easily because counter electromotive force is generated at the contact.

- Deposition, defective insulation or defective contact at the relay contact
- Damage of any electric parts due to high-voltage generated inside the detector head
- Abnormal operations by an out-of-control CPU



CAUTION

- In principle, do not activate inductive load at the alarm contact of the detector head. (In particular, never use the inductive load to activate a fluorescent lamp or motor.)
- If inductive load is activated, relay it with an external relay (contact amplification). However, because the coil of an external relay also involves inductive load, select a relay at a lower voltage (100 VAC or below), and then protect the contact of the detector head with an appropriate surge absorbing part, such as a CR circuit.

If load is to be activated, appropriate measures must be taken to stabilize the operation of the detector head and protect the alarm contact referring to the following information.

- Relay it with an external relay at a lower voltage of 100 VAC or below (contact amplification). At the same time, the surge absorbing part SK1 suitable for the specifications must be attached to the external relay.
- In addition, the surge absorbing part SK2 must be attached to the loaded side of the external relay if necessary.
- It may be recommended that the surge absorbing part should be attached to the contact for certain load conditions. It must be attached to an appropriate position by checking how the load is activated.

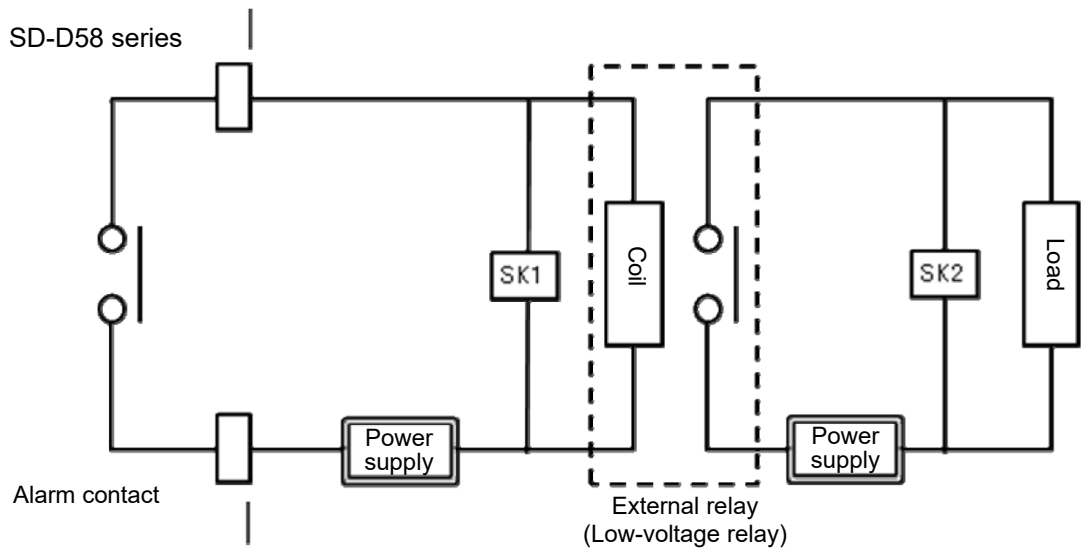

* SK1, SK2: Surge absorbing parts

4-4. How to install

<Installation Dimensions and Maintenance Space>

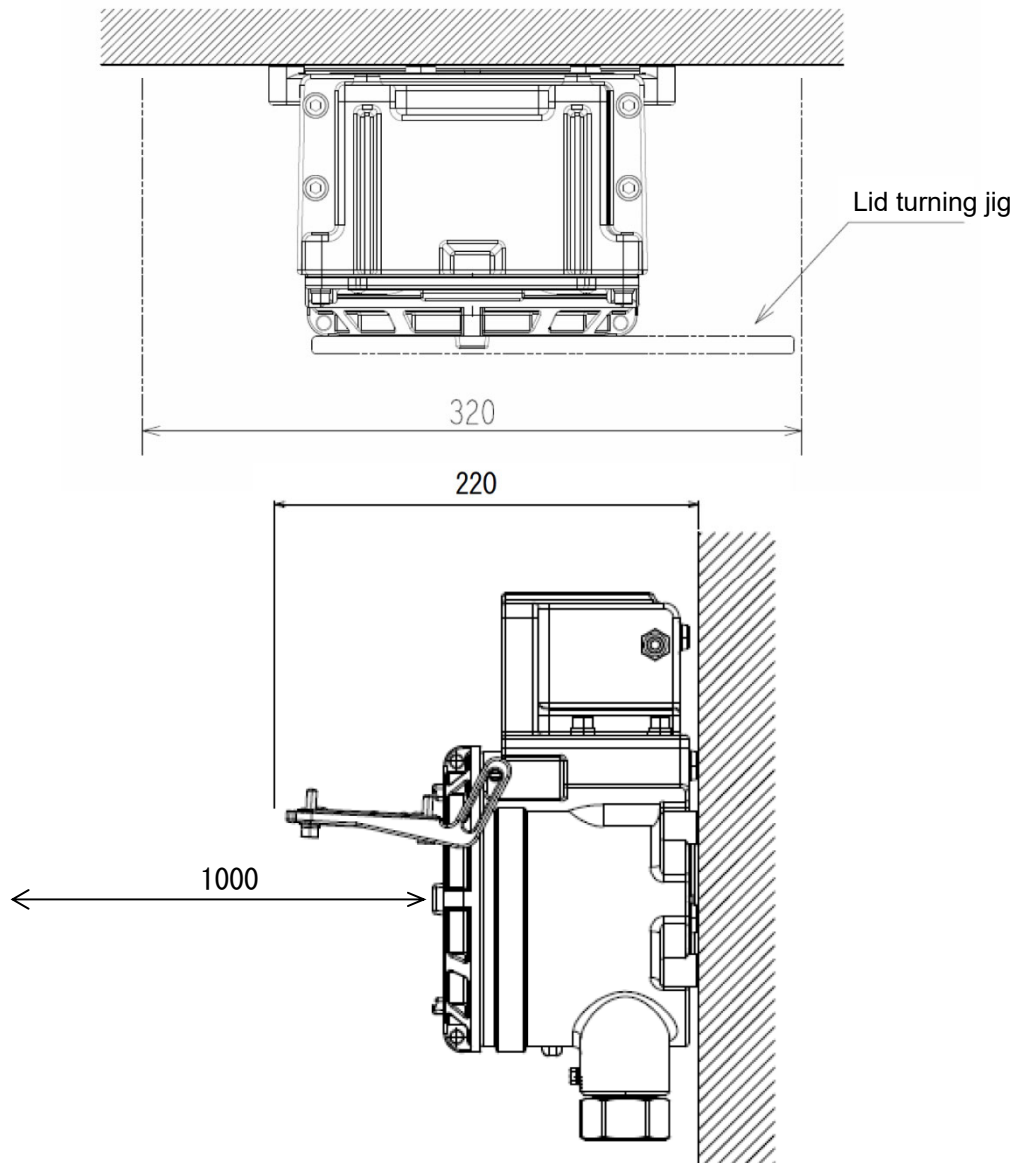

Unit: mm

The following installation requirements must be met to install the detector head.

- Attach the detector head on the wall and others using four M6 screws.
- Tighten the hexagon socket head cap bolt fixing the lid and the main body with a tightening torque of $215.6 \pm 24.5 \text{ N} \cdot \text{cm}$.
- When closing the lid of the detector, make sure that there is no dust on screw, surfaces of the main body and lid. Then apply grease as specified by RIKEN KEIKI.

**CAUTION**

Do not install the detector head in a place where maintenance of the detector head cannot be performed or where handling the detector head involves dangers.

Regular maintenance of the detector head must be performed.

Do not install the detector head in a place where the machinery must be stopped when maintenance is performed in its inside, where parts of the machinery must be removed to perform maintenance, or where the detector head cannot be removed because tubes or racks prevent access to it. Do not install the detector head in a place where maintenance involves dangers, for example, near a high-voltage cable.

**CAUTION**

•Grease specified by RIKEN KEIKI : BARRIERTA JFE 552 (manufactured by NOK KLUBER)

If you can not prepare the specified grease, use one that meets the following requirements.

1. Material does not harden due to deterioration
2. Volatile solvent-free
3. Material does not cause corrosion at the surface
4. Silicon-free
5. Validation of suitability depends on the specifications of grease manufacturer

4-5. How to wire



DANGER

- Do not put a metal object or other foreign substances inside the external connection terminal box when attaching the lid.
- Ignoring this may damage the device or impair the explosion-proof performance.
- Draw the cable to the detector by the means that do not impair the explosion-proof performance.



CAUTION

- Be careful not to damage the internal electronic circuit when wiring. In addition, be careful not to apply stresses on the detector head when (overweight) cables are installed.
- The power cables and signal cables must not be installed together with the motor power cables, etc. When these cables must be installed together for unavoidable reasons, put the power cables and signal cables in a metal conduit. The conduit must be connected to a grounding circuit.
- When stranded wires are used, prevent wires from contacting each other.
- Use the dedicated handling lever to wire.
- Use appropriate cables to wire.

<Recommended Cables>

SD-D58•AC

Power cable	CVV, etc. (1.25mm ² or 2.0mm ²) - 2-core or 3-core
Contact and transmission cable	(When the contact isn't used) Shielded cable of CVVS, etc. (1.25 mm ² or 2.0mm ²) - 2-core (When the contact is used) Shielded cable of CVVS, etc. (1.25mm ² or 2.0mm ²) - 4-core

SD-D58•DC

Contact and transmission cable	(When the contact isn't used) Shielded cable of CVVS, etc. (1.25mm ² or 2.0mm ²) - 3-core (When the contact is used) Shielded cable of CVVS, etc. (1.25mm ² or 2.0mm ²) - 5-core
--------------------------------	---

<Parts. Length table of outside conductor lead-in>

<ATEX Specifications> <Taiwan Ex(TS) Specifications>

Cable outer diameter (mm)	Rubber seal inner diameter (mm)	Washer inner diameter (mm)	Eccentric washer inner diameter (mm)	Eccentric washer outer diameter (mm)	amount of eccentricity (mm)
φ9.0 -φ9.6	φ10	φ10	φ9.8	φ20	2.5
φ9.6 -φ11.0	φ11	φ14	φ11.8	φ20	1.5
φ11.0 -φ12.0	φ12	φ14	φ12.8	φ20	1.5
φ12.0 -φ12.5	φ12.5	φ14	φ12.8	φ20	1.5
φ12.5 -φ13.5	φ13.5	φ14	φ13.8	φ20	1.5
φ13.5 -φ14.5	φ14.5	φ17	φ14.8	φ22	1.5
φ14.5 -φ15.5	φ15.5	φ17	φ15.8	φ22	1.5
φ15.5 -φ16.0	φ16.5	φ17	φ16.2	φ22	1
No cable	- (Plug)				

<Japan Ex Specifications>

Cable outer diameter (mm)	Rubber seal inner diameter (mm)	Washer inner diameter (mm)	Eccentric washer inner diameter (mm)
φ9.0 (allowable range:φ9.0 - φ9.6)	φ10	φ14	φ9.8
φ9.6 (allowable range:φ9.0 - φ9.8)	φ11	φ14	φ9.8
φ10.5 (allowable range:φ10.5 - φ11.0)	φ11	φ14	φ11.8
φ11.0 (allowable range:φ11.0 - φ11.5)	φ12	φ14	φ12.8
φ11.5 (allowable range:φ11.5 - φ12.0)	φ12	φ14	φ12.8
φ12.0 (allowable range:φ12.0 - φ12.5)	φ12.5	φ14	φ12.8
φ13.0 (allowable range:φ13.0 - φ13.5)	φ13.5	φ14	φ13.8
φ16.0 (allowable range:φ16.0 - φ16.2)	φ16.5	φ17	φ16.2
No cable	- (Plug)		

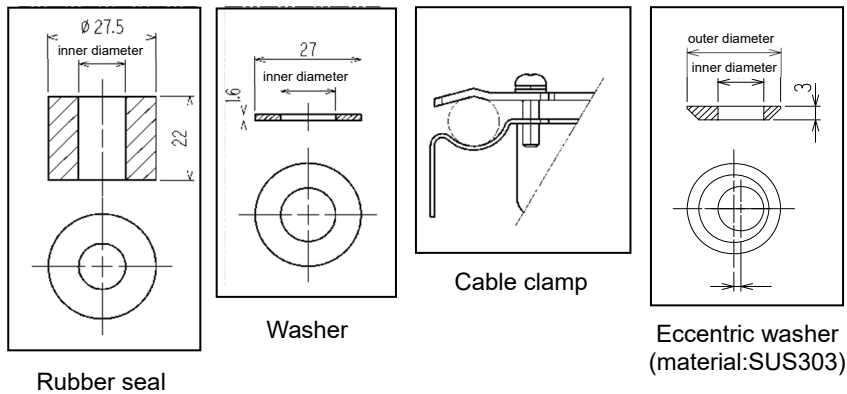

NOTE

- The following table shows an example of the outer diameter of the cables. Use them for reference. The outer diameters must be checked because they somewhat vary between manufacturers.

Number of core	CVV 1.25mm ²	CVV 2.0mm ²	CVVS 1.25mm ²	CVVS 2.0mm ²
2	φ 9.2	φ 10.5	φ 9.6	φ 10.5
3	φ 9.7	φ 11.0	φ 10.5	φ 11.0
4	φ 10.5	φ 11.5	φ 11.0	φ 12.0
5	φ 11.5	φ 12.5	φ 12.0	φ 13.0
6	φ 12.5	φ 13.5	φ 13.0	φ 14.0

<Figure of Terminal Plate>

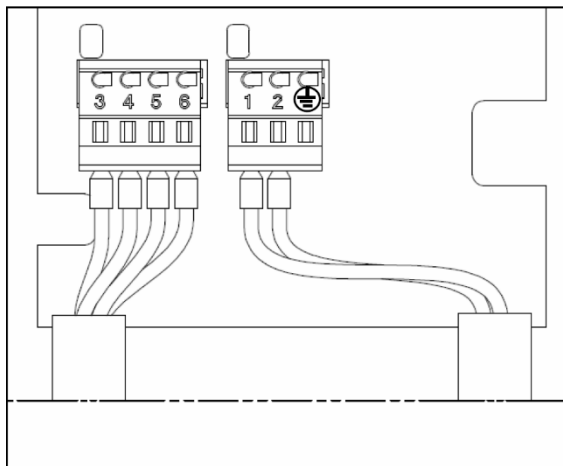

※SD-D58·AC

SD-D58·AC

3	4	5	6	1	2	
contact	contact	Sig. (+)	Sig. (-)	AC (L)	AC (N)	FG
4-20mA Output + HART *				100-110VAC input		

SD-D58·DC

1	2	3	4	5
DC (+)	DC (-) common	Sig. (+)	contact	contact
24VDC input		4-20mA Output + HART *		

* Only TYPE GP H and TYPE NC H.

NOTE

Open the electric circuit lid.

Remove the electric circuit lid and display unit to find behind them the terminal plate shown in the figure above.

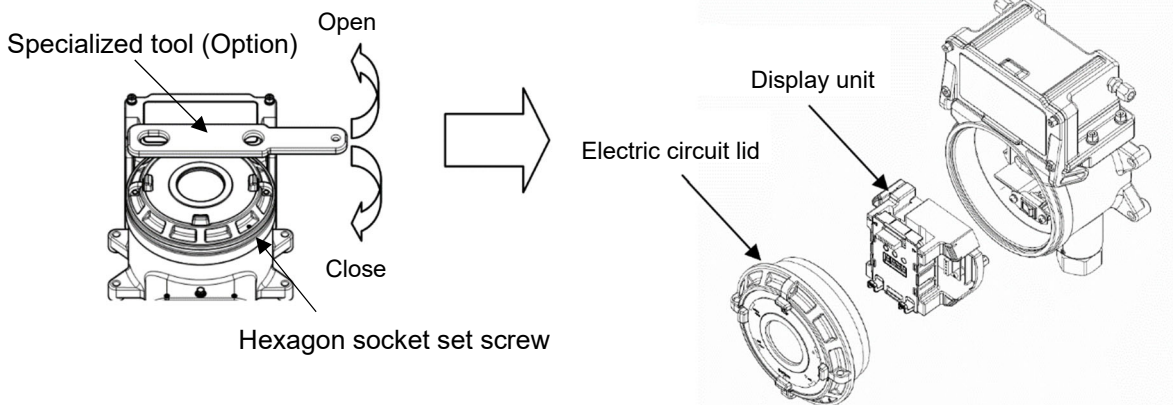

- Power input terminal plates are SD-D58·AC: 3-pole and SD-D58·DC: 2-pole.
- After use, closely tighten the lid until the thread is no longer seen (clockwise 8 rotations +1/4 rotation or more) and the "TOP" marking faces upward. Tighten the hexagon socket set screw with a tightening torque of 107.8±12.7 N·cm.

<Specifications of Terminal Plate>

Specifications of terminal plate

- Rated voltage: 250 VAC
 - Rated current: 12 A
- However, it depends on cables to be used.

Connection conditions

- Cables: 0.25 - 2.5 mm²
- Bare wire length: 8 - 9 mm
- Connecting tool: Dedicated handling lever (accessory) or driver (edge 3.5 x 0.5 mm)



CAUTION

The specified bare wire length must be observed when the wire insulation is peeled off. Improper clamping of the wire due to a shorter bare wire length may cause defective electric conduction or heating. Catching the wire insulation due to a shorter bare wire length may cause defective electric conduction or heating. Exposing the wire due to a longer bare wire length may cause defective insulation or a short circuit. Be careful not to break up the wire. If the wire is broken up when inserted to the terminal, this may cause defective insulation or heating.

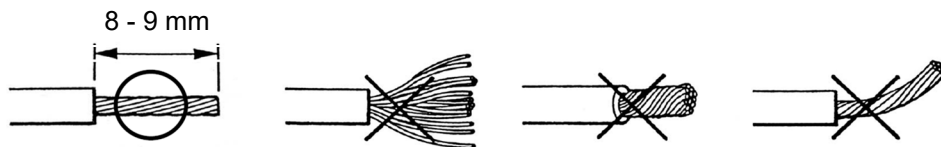

Compatible bar terminal

For a bar terminal, the following items are available.

- Bar terminal (ferrule): Model 216 Series (manufactured by WAGO)
- Crimping tool: Model VarioCrimp 4 (206-204) (manufactured by WAGO)



CAUTION

A bar terminal of the specified model must be used. Using other bar terminals invalidates the warranty of the performance.

<How to Connect to Terminal Plate>

When cables are connected to the connectors, use the dedicated lever or a flathead screwdriver to do it as shown below.



CAUTION

- The appropriate tools must be used.
- In principle, one wire can only be connected to one wiring hole.
- When the wire is inserted into the driver slot by mistake, it does not contact the conductive part. This may cause defective electric conduction or heating. When the wire is inserted under the spring by mistake, it does not contact the conductive part. This may cause defective electric conduction or heating.

NOTE

<How to Use the Dedicated Handling Lever>



Push the lever with your finger to lower the spring in its inside.



While holding down the lever, insert the wire into the (round) wiring hole until it reaches the deepest point. Once the lever is released, the wire is secured.

To check whether the wire is connected securely, pull the wire gently. (Do not pull the wire strongly.)

<Attaching External Cables and Plugs>

As shown on the figure below, attach the parts in the following order: cable gland, eccentric washer, washer, and rubber seal to the cable, then connect the cable into the main unit, then screw the cable gland to tighten the rubber seal. When installing the cable gland, wipe the cable gland mounting part, the hexagon socket set screw, the grounding screw, and the cable gland and wipe the specified grease.

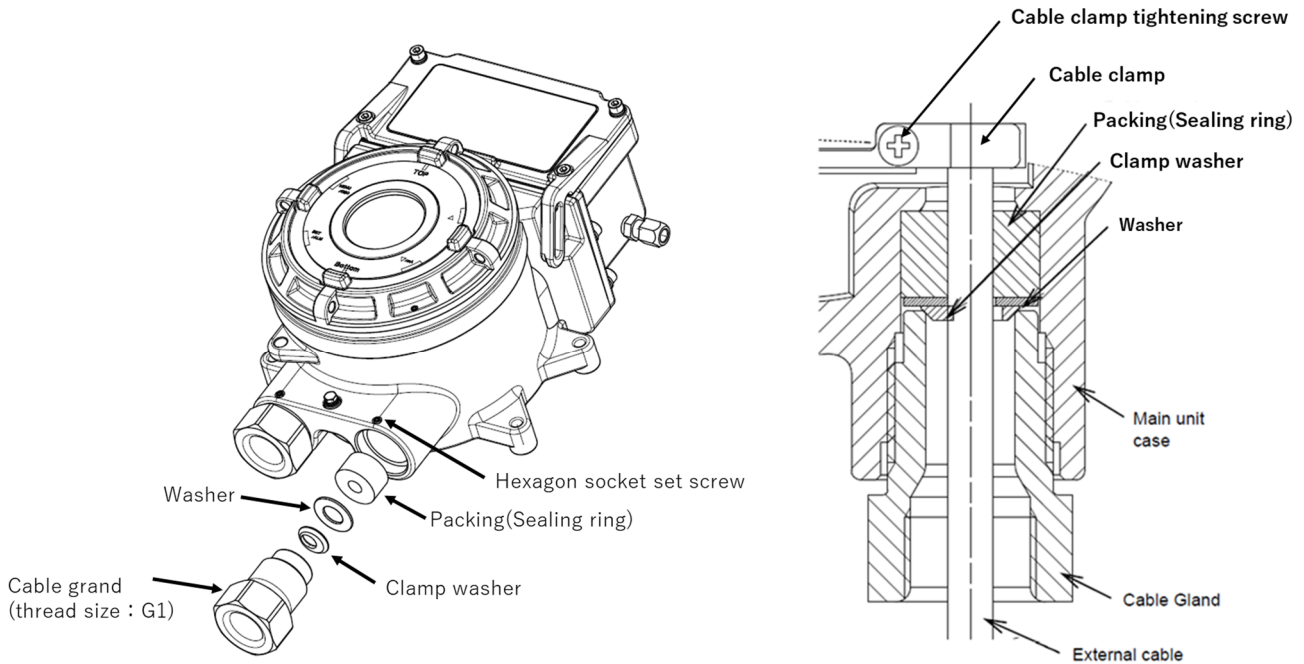

CAUTION

- Cable gland must be tightened with $40\text{N} \cdot \text{m}$ or more of torque.
- Maximum surface roughness of the enclosure face for sealing is $\text{Ra}6.3\mu\text{m}$.
- When installing the plug instead of the cable gland, tighten the plug to $40\text{N} \cdot \text{m}$.
- Tighten the hexagon socket head cap screws fixing the cable gland with a tightening torque of $107.8 \pm 12.7\text{N} \cdot \text{m}$.





CAUTION

• Grease specified by RIKEN KEIKI : BARRIERTA JFE 552 (manufactured by NOK KLUBER)
If you can not prepare the specified grease, use one that meets the following requirements.

1. Material does not harden due to deterioration
2. Volatile solvent-free
3. Material does not cause corrosion at the surface
4. Silicon-free
5. Validation of suitability depends on the specifications of grease manufacturer

<Grounding>

Connect the detector head to your grounding terminal with the external grounding terminal .



WARNING

- Before turning on the detector head, do not forget to connect it to a grounding terminal.
- For stable operation of the detector head and safety, it must be connected to a grounding terminal. Do not connect the grounding wire to a gas pipe.
- The grounding must be made as D type grounding (below 100 Ω of grounding resistance).
- For the grounding wire, use cable lugs to safely connect it to a grounding terminal without looseness or twist.
- To connect the grounding wire to the internal grounding terminal of the unit, use a crimped terminal to which a wire with a cross-section area of 4 mm² or more can be attached.

<Wiring Example>

SD-D58·AC

Connecting to the indicator

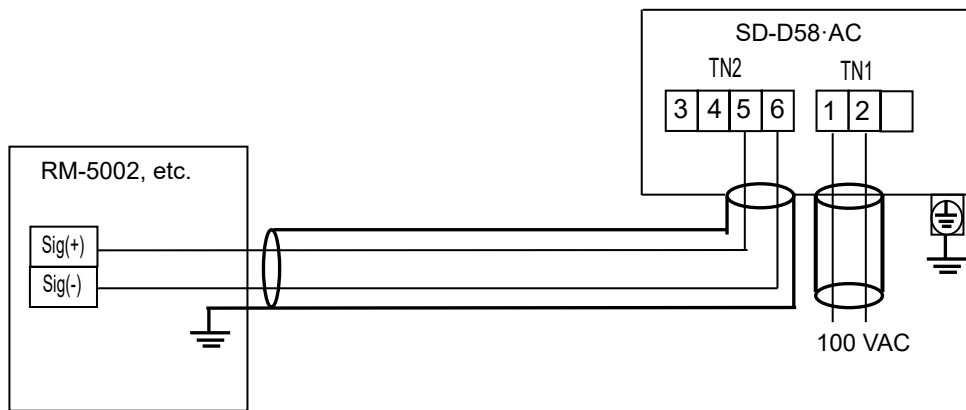

Connecting to the upper unit (DCS, PLC)

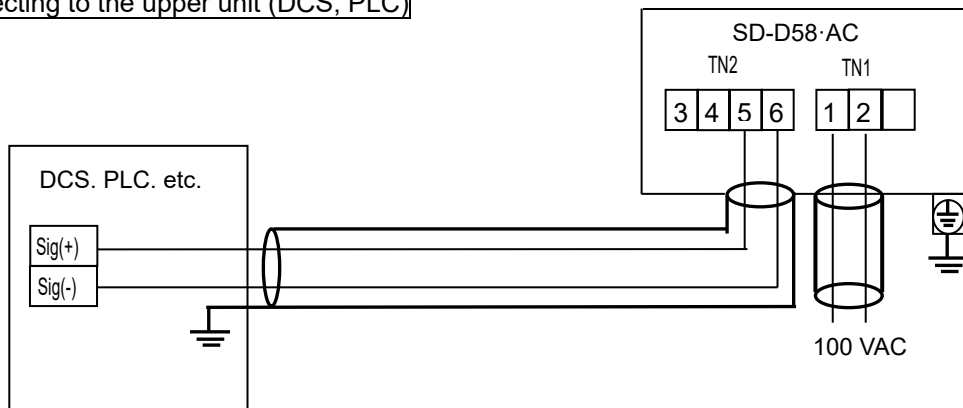

SD-D58·DC

Connecting to the indicator 【3-core·4-20mA】

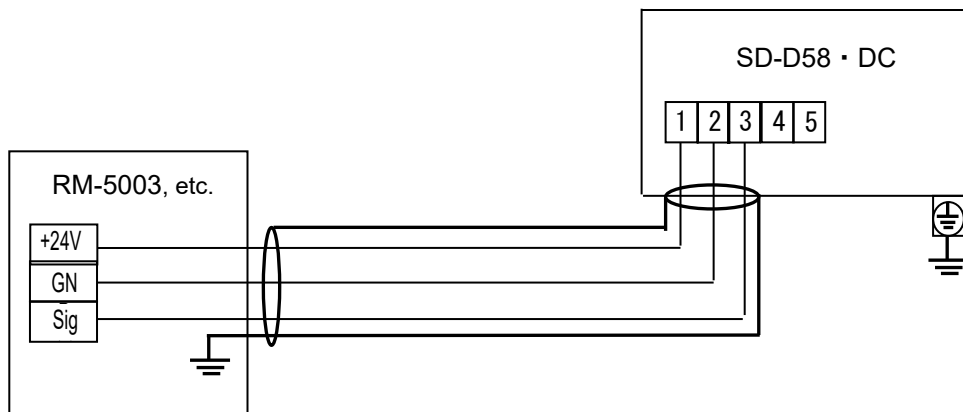
**WARNING**

- If HART communication is used, check so that wiring load resistance that constitute 4-20mA loops, amount to 250 Ω -300 Ω .

4-6. How to tube

The detector head has an Rc1/8 thread inside of the sampling inlet/outlet (GAS IN, GAS OUT), to which BS unions are attached as standard. Because their material varies depending on the gas to be detected, please specify the material.

The compatible tube is a copper tube of $\phi 8$ (OD) - $\phi 6$ (ID). The tube must be installed with the supplied sleeves attached to prevent a leak.

When the tube is cut, its cut point may have a smaller inner diameter. Use a file etc. to expand the inner diameter of the cut point. To remove cut-dust remaining inside of the tube, blow compressed air etc. into the tube before connecting it to the detector head.

Some sample gases have highly adsorptive or corrosive properties. Select the tube material taking into account these precautions.



WARNING

- The detector head is designed to draw gases under the atmospheric pressure. If excessive pressure is applied to the sampling inlet and outlet (GAS IN, GAS OUT) of the detector head, detected gases may be leaked from its inside, thus leading to dangers. Avoid applying excessive pressure to the detector head while in use.
- Gases must be exhausted from the gas exhausting outlet (GAS OUT) to which an exhaust tube is connected, to a point regarded as a safe place.
- Do not use the detector head in the presence of silicone or sulfides. The gas sensing part of the gas sensor and flow sensor is made of metal porous sintered alloy permeated with an oxidation catalyst. If silicon or sulfide compounds are accumulated on the surface of porous sintered alloy, the area of the gas sensing part becomes smaller, which may result in serious deterioration of its sensitivity.
- Do not use the detector head under an inert gas atmosphere. The gas cannot be detected correctly under an inert gas atmosphere such as He.



CAUTION

- The longer the tube of the GAS IN is, the longer it takes for a sample gas to reach the detector head. The length of the GAS IN tube must be minimized, since some gases have a highly adsorptive property which results in slower responses, and possibly a lower reading than the actual value.
- When the humidity in the sampling point is high, condensation may be formed inside the tube. (Make sure to avoid condensation when using a gas such as a strong acid gas, which is dissolved into water and corrodes contacted materials, because it may result in undetectable condition and furthermore may corrode internal parts.) Also avoid an excessive U-shaped or V-shaped tube piping.
- Determine the inlet for the sample gas, considering the air flow of the sample gas line and the gas generating process.
- To remove dust, never fail to attach the supplied dust filter in the middle of the tube.
- The tube (length and material) must be decided. Please contact RIKEN KEIKI for more information.
- Do not use the detector head under an inert gas atmosphere. The flow rate cannot be detected correctly under an inert gas atmosphere such as He.
- During tubing work, do not bend tubes at a right angle but install them as straight as possible. Applying too much load on a tube may put too much strain on the pump of the detector head and shorten the pump life. If bending of a tube is unavoidable, bend it with an appropriate radius to minimize strain.

5

How to Operate

5-1. Preparation for start-up

Before supplying power, read and understand the following precautions. Ignoring these precautions may cause an electric shock or damage the detector head.

- Connect the detector head to a grounding circuit.
- Check that the wiring is connected to external device properly.
- Check that the power supply voltage is compliant with the specifications.
- Because the external contact may be activated during the adjustment, take measures to prevent an activated contact from having influences on external device.

5-2. Basic operating procedures

Normally, the detection mode is activated after the power is turned on.

PW : POWER	● : 点灯
A : ALM	○ : 消灯
F : FAULT	◎ : 点滅
L : L range lamp	
H : H range lamp	

The detector head is restarted after recovering from fault.

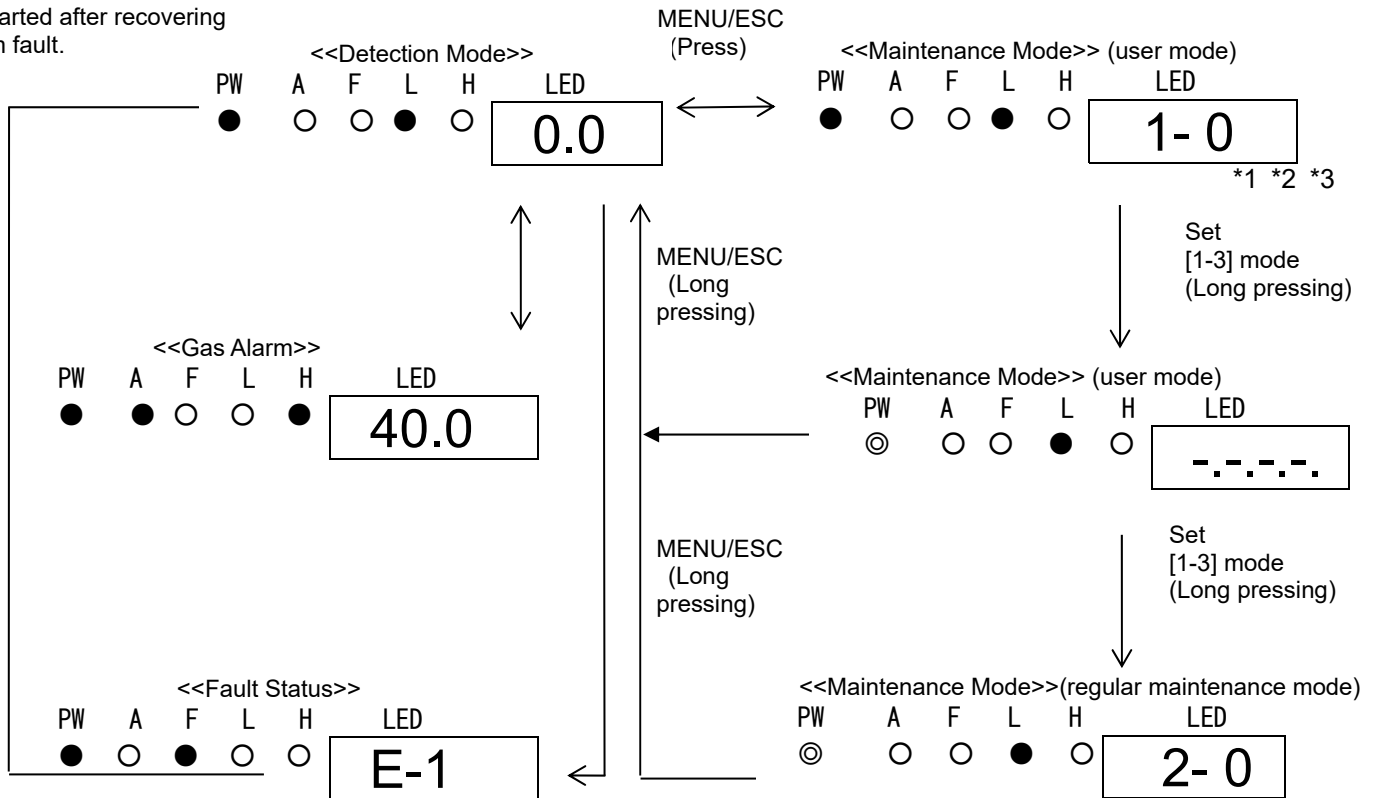

*1 Only for TYPE NCW there are L range lamp and H range lamp.

*2 Long pressing of MENU/ESC key

While the MENU/ESC key is pressed, the screen displays ". . .".

*3 Lighting of the range lamp in the maintenance mode indicates whether the indication of the gas concentration being measured is in the L range or the H range. However, when the alarm point is set, the set value (or density value)When it is displayed, it indicates whether the set value (or concentration value) being displayed is in the L range or the H range.



WARNING

When the detector head enters other mode from the detection mode while an alarm is activated, the alarm is reset.

5-3. How to start the detector head

- Before supplying power (100 VAC) to the detector head, check that the detector head is installed properly.
 - Open the electric circuit lid.*
 - Turn ON the power switch. *
 - Close the electric circuit lid.*
 - Supply power (100 VAC) to the detector head.
 - After the detector head completes the start-up, it enters the detection mode swiftly.
- * Only SD-D58·AC has a power switch. Since SD-D58·DC does not have any power switch, there is no need to open or close the electric circuit lid.



CAUTION

- Do not turn off the detector head during the initial clear. The detector head is reading the internal memory during the initial clear.
- If the detector head is installed newly or the new sensor is replaced, the sensor must be warmed up for a specified period which is determined depending on the type of the sensor after the detector head is started.
- After the warm-up is completed, perform a gas calibration.

NOTE

<<Start-up Operation Procedures>> (approximately 25 seconds for system check of the detector head and alarm deactivation)

Power on -> Initial clear (approximately 25 seconds) -> Detection mode

Power on



Initial clear

PW	A	F	L	H	LED
●	●	●	●	●	8.8.8.8.



Detection mode

●	○	○	○	○	---
---	---	---	---	---	-----



●	○	○	●	○	0.0
---	---	---	---	---	-----

* Only for TYPE NCW there are L range lamp and H range lamp.

5-4. Modes

Details on each mode are provided as follows.



CAUTION

Do not change the settings if not necessary. Changing the settings without understanding the specifications may cause malfunctions.

Mode	Item	LED display	Details
Detection mode	—	Gas concentration	Normal state.
Maintenance mode (User)	ROM/SUM display	1-0	Displays the program version and others. This is not typically used by the user.
	Zero adjustment	1-1	Performs the zero adjustment.
	Setting display	1-2	Displays various setting values.
	Switches to regular maintenance mode	1-3	Switches to the regular maintenance mode.
Maintenance mode (Regular maintenance)	Test mode	2-0	Performs various tests. 2-0.0 Gas test 2-0.1 Alarm test 2-0.2 Fault alarm test 2-0.3 LED test 2-0.4 Memory test
	Zero adjustment	2-1	Performs the zero adjustment.
	Span adjustment	2-2	Performs the span adjustment.
	Zero/span initialization	2-3	Initializes zero/span values.
	Environmental setting	2-4	Used for various environmental settings. 2-4.0 Heater voltage adjustment 2-4.1 INHIBIT setting 2-4.2 Alarm setpoint setting 2-4.3 Alarm delay time setting 2-4.4 Alarm pattern setting 2-4.5 Zero suppression pattern setting 2-4.6 Zero suppression value setting 2-4.7 Alarm contact specification setting 2-4.8 Energized/de-energized contact setting 2-4.9 Zero follower selection 2-4.A Maintenance mode external output setting 2-4.B External output setting 2-4.C Alarm test external output setting 2-4.D Sensor operation start setting 2-4.E Password setting 2-4.F Sensor fault alarm pattern setting 2-4.U Double range external output setting*
	Electrical setting display	2-5	Displays various electrical settings. This is not typically used by the user.
	Flow sensor setting	2-6	2-6.0 Flow sensor heater voltage adjustment 2-6.1 Flow rate zero point setting 2-6.2 Low flow rate threshold value setting 2-6.3 Flow sensor zero point check 2-6.4 Flow sensor output check 2-6.5 Pump output check 2-6.6 Flow sensor initialization 2-6.7 Flow sensor operation start setting 2-6.8 Low flow rate alarm delay time setting 2-6.9 Flow sensor function ON/OFF setting
	Flow sensor various setting display	2-7	Displays various settings of the flow sensor. This is not typically used by the user.
	Switch to factory mode	2-8	Not used.
	Switch to user mode	2-9	Returns to the user mode.

*There is "2-4.U Double range external output setting" only for TYPE NCW.

5-5. Maintenance mode (User)



WARNING

After the adjustment is completed, do not forget to press MENU/ESC key to return to the detection mode.
 (If the detector head remains in the maintenance mode, it automatically returns to the detection mode in ten hours.)

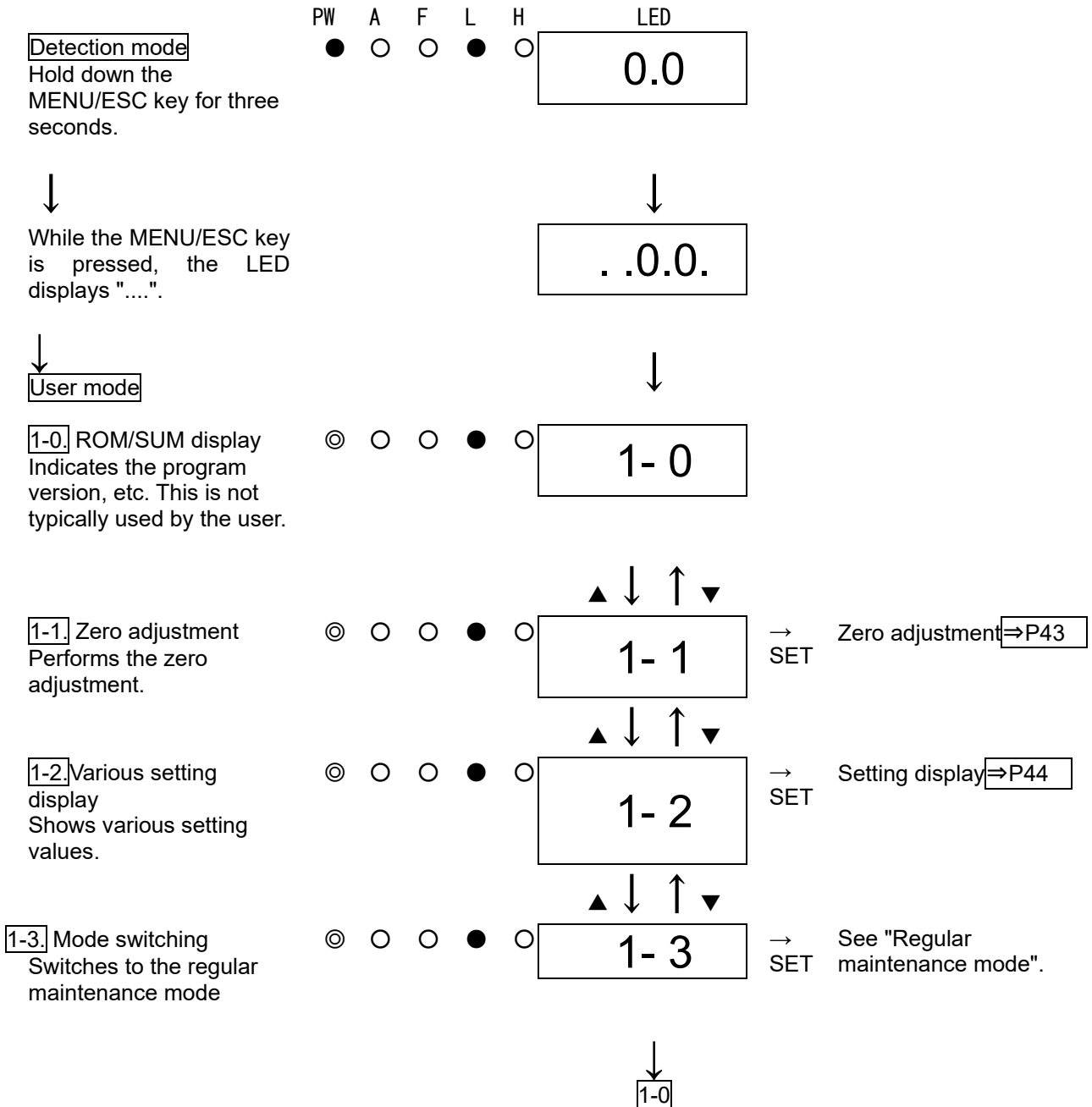

* Only for TYPE NCW there are L range lamp and H range lamp.

<Zero Adjustment "1-1">

This is used to perform the zero adjustment.

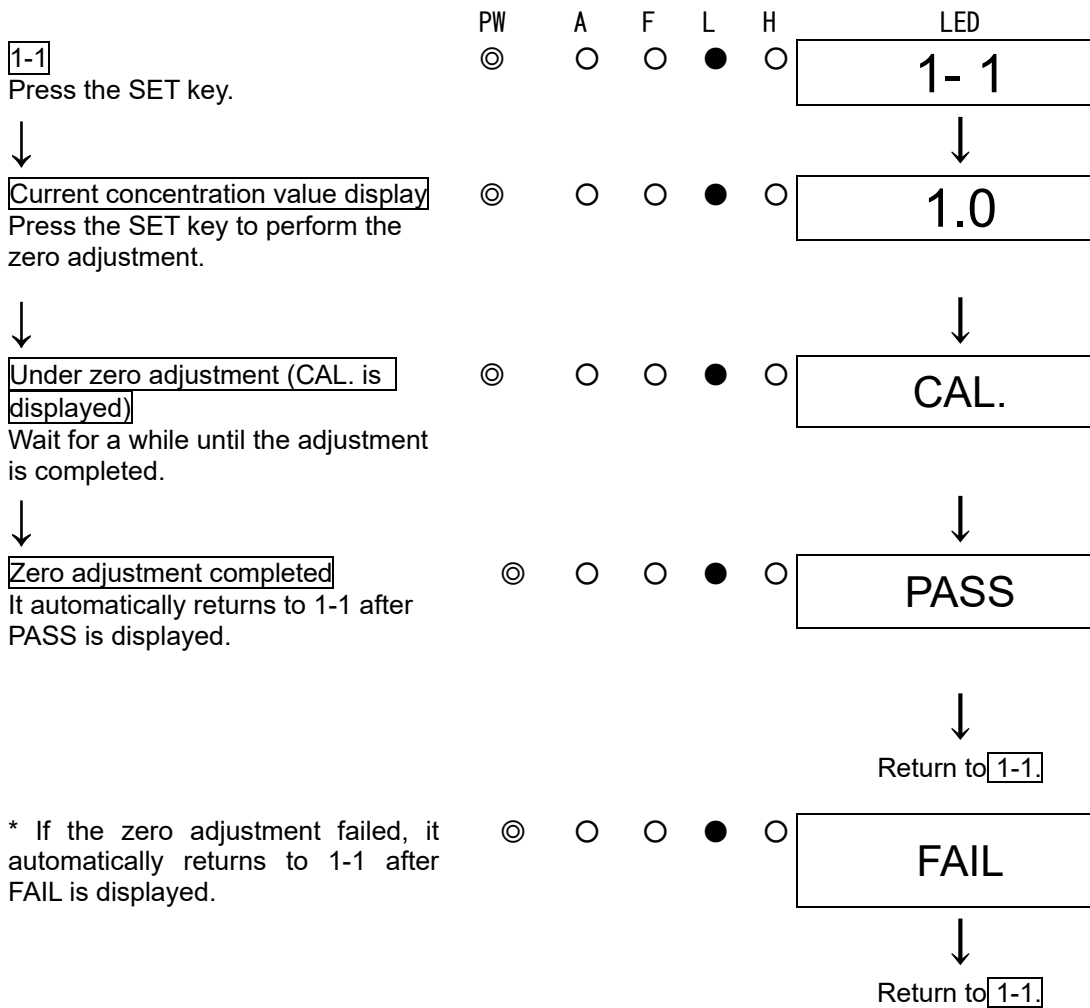

* Only for TYPE NCW there are L range lamp and H range lamp.

NOTE

If the zero adjustment failed since the zero point was significantly fluctuated from around zero, it returns to 1-1 after FAIL rather than PASS is displayed. In this case, the zero adjustment has not been completed.

<Setting Display "1-2">

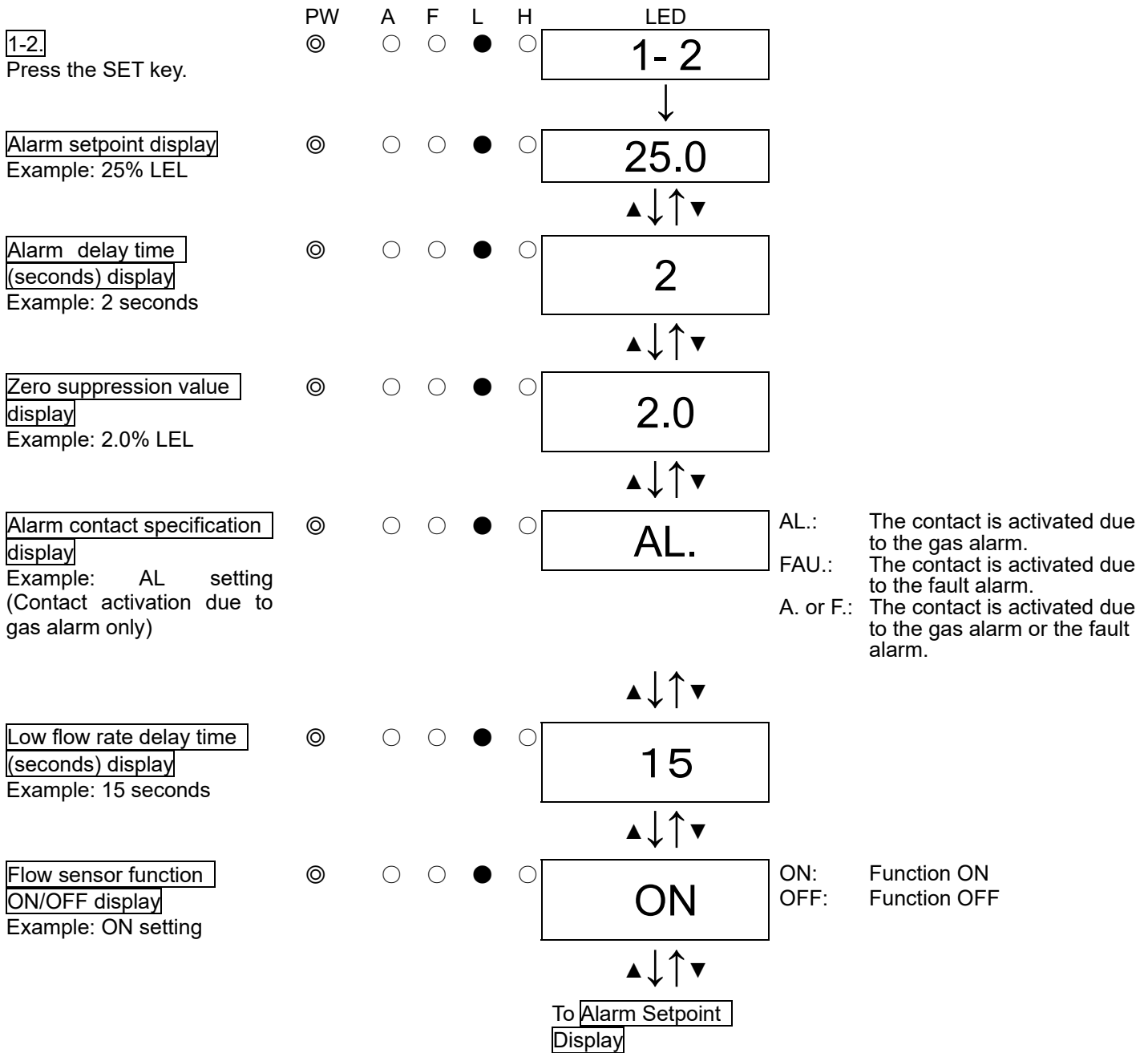

* Only for TYPE NCW there are L range lamp and H range lamp.

5-6. How to exit

- Turn OFF the power switch of the indicator/alarm unit.
 - Turn off the power supply to the detector head.
 - Open the electric circuit lid.*
 - Turn OFF the power switch of the detector head.
 - Close the electric circuit lid.*
- * Only SD-D58-AC has a power switch. Since SD-D58-DC does not have any power switch, there is no need to open or close the electric circuit lid.



WARNING

- When the detector head is turned off, an alarm may be triggered on the upper (central) system.
- Before turning off the detector head, INHIBIT (point skip) on the upper (central) system must be activated. Decide whether the power can be turned off by checking the operation of the devices connected to the external output or external contact output terminal of the detector head.
- If the alarm contact is energized (option), it is activated when the detector head is turned "OFF".

6

Operations and Functions

6-1. Gas alarm activation

Gas alarm: Triggered when the concentration of detected gas reaches or exceeds the alarm setpoint value. <<Auto-Reset>>

NOTE

The alarm setpoint is factory-set. Although the alarm delay time (standard: 2 seconds) works in the detector head to prevent a false activation, it can be cancelled if not needed.

<Display Operation>

Gas concentration display

In case of over the detection range (Over Scale), "□□□□" is displayed on the LED.

Power indicator lamp (POWER: Green)

During normal operation, this lights up continuously.

Alarm indicator lamp (ALM: Red)

It lights up when the alarm setpoint value is reached to or exceeded.

L range lamp (Red)

Only for TYPE NCW there are L range lamp.

It lights when gas is detected in the low concentration range.

H range lamp (Yellow)

Only for TYPE NCW there are H range lamp.

It lights up when it switches to the high concentration range beyond the measurement range on the low density side.

<Contact Activation>

The contact is activated when the gas concentration reaches or exceeds the alarm setpoint value. The contact activation is reset automatically when the gas concentration drops below the alarm setpoint value.

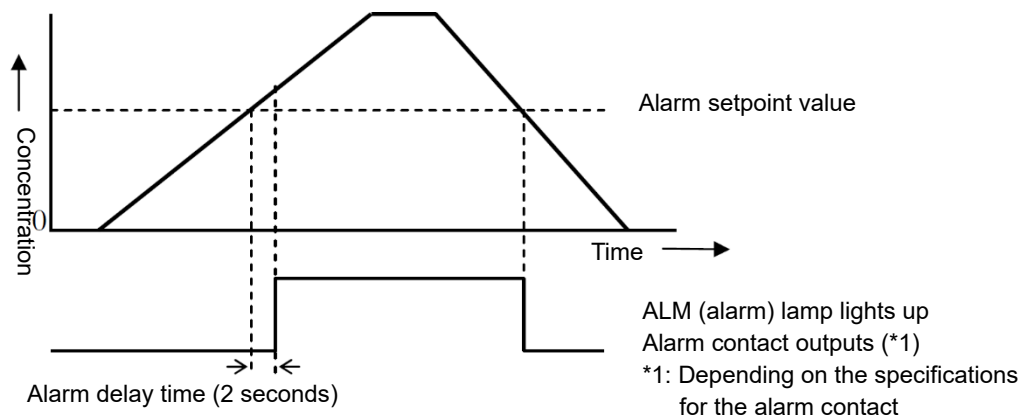

<Response to Gas Alarm>

A gas concentration value exceeds the alarm setpoint

When a gas alarm is triggered, take actions in accordance with your management rules of gas alarm. Normally, take the following actions.

- Check the reading of the detector head.

NOTE

If a gas leak is momentary, the reading may already have dropped when checking it. In addition, when the alarm is triggered by noise or other incidental conditions other than a gas, the reading may have already dropped.

- Based on your management rules of gas alarm, no one can be allowed to access the monitored zone to ensure safety.
- If the gas concentration display continues to be displayed, close the main valve of the gas, and then check that the gas concentration reading dropped.
- Access the gas leak point, equipped with a protective gear to avoid dangers caused by possibly remaining gases, and check whether gases remain or not by using a portable gas detector.
- Check that the point is free from dangers, and take actions to fix the gas leak.

6-2. Fault alarm activation

A fault alarm is triggered when the detector head detects abnormalities. After a fault alarm is triggered, the fault lamp (yellow) lights up and an error message is displayed on the LED. Determine the causes and take appropriate actions.

After the detector head is successfully returned from the fault, it restarts with the process normally performed right after it is turned on (initial clear).

If the detector head has problems and is repeatedly malfunctioning, contact RIKEN KEIKI immediately.

NOTE

For information on malfunctions (error messages), see "9. Troubleshooting".

6-3. Low Flow Rate Abnormal Operations

<Contact Activation>

The contact is activated when the output value of the low flow sensor drops below the alarm setpoint (if the flow sensor function ON is selected).

The contact activation is auto-reset when the flow rate exceeds a certain level.

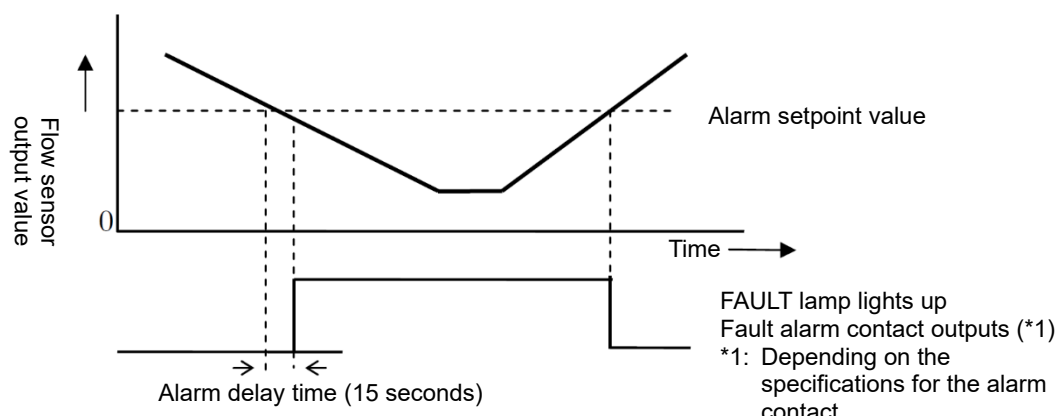

NOTE

A low flow rate abnormality can be a cause of fault alarm contact output.
For information on malfunctions (error messages), see "9. Troubleshooting".

6-4. External output operation

Signal transmission system		Electric current transmission (non-isolated) 4 – 20 mA
Transmission path		CVVS
Transmission distance		CVVS 1.25mm ² : Maximum 1 km 2.0mm ² : Maximum 2.0 km
Connection load resistance		Below 300 Ω
1	Detection mode (No alarm)	4 - 20 mA (concentration output)
2	Detection mode (Gas alarm)	4 - 20 mA (concentration output)
3	Initial clear	Depending on the setting of section 4. <u>2.5 mA setting</u> : 2.5 mA <u>4 mA, HOLD, 4 - 20 mA setting</u> : 4 mA
4	Maintenance mode	<u>2.5 mA setting</u> : 2.5 mA <u>4 mA setting</u> : 4 mA <u>HOLD setting</u> : Hold previous value before the maintenance mode is entered <u>4-20 mA setting</u> : 4 - 20 mA (concentration output)
5	Alarm test	<u>Output ON setting</u> : 4 - 20 mA (concentration output) <u>Output OFF setting</u> : 4 mA
6	Fault alarm	0.5 mA (Fixed)
7	INHIBIT	Depending on the setting of section 4. <u>2.5 mA setting</u> : 2.5 mA <u>4 mA, HOLD, 4 - 20 mA setting</u> : 4 mA
8	Power Off	0mA

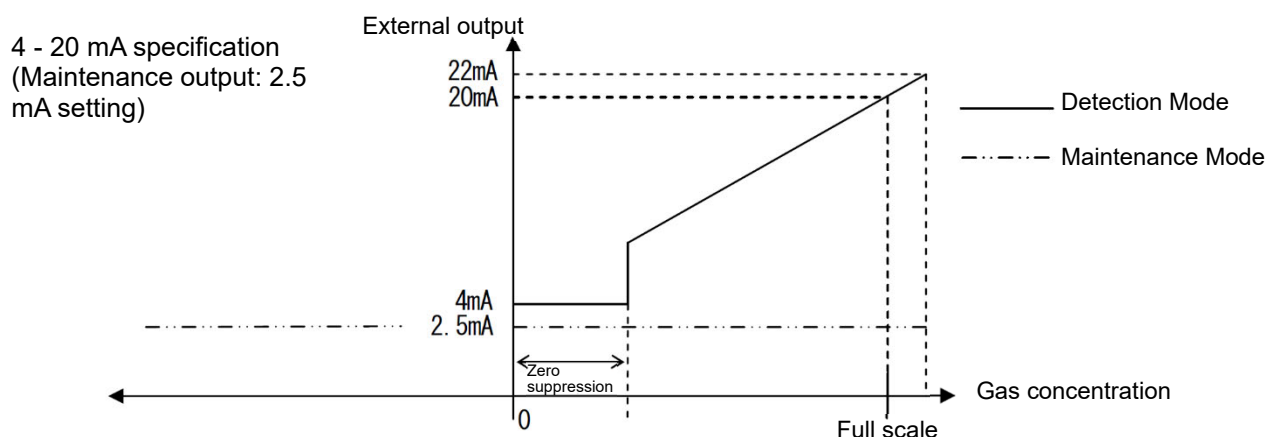
Example of gas concentration and external output other than TYPE NCW**CAUTION**

- The 4 - 20 mA output is already adjusted. In case of over scale, an output will not exceed 22 mA.
 - Output during INHIBIT or initial clear is based on 4 - 20 mA output setting in the maintenance mode.
- In particular, when the detector head is started or the specification is changed, be careful about 4-20 mA output setting. Understand how the detector head functions, and take actions, if

Example of gas concentration and external output TYPE NCW

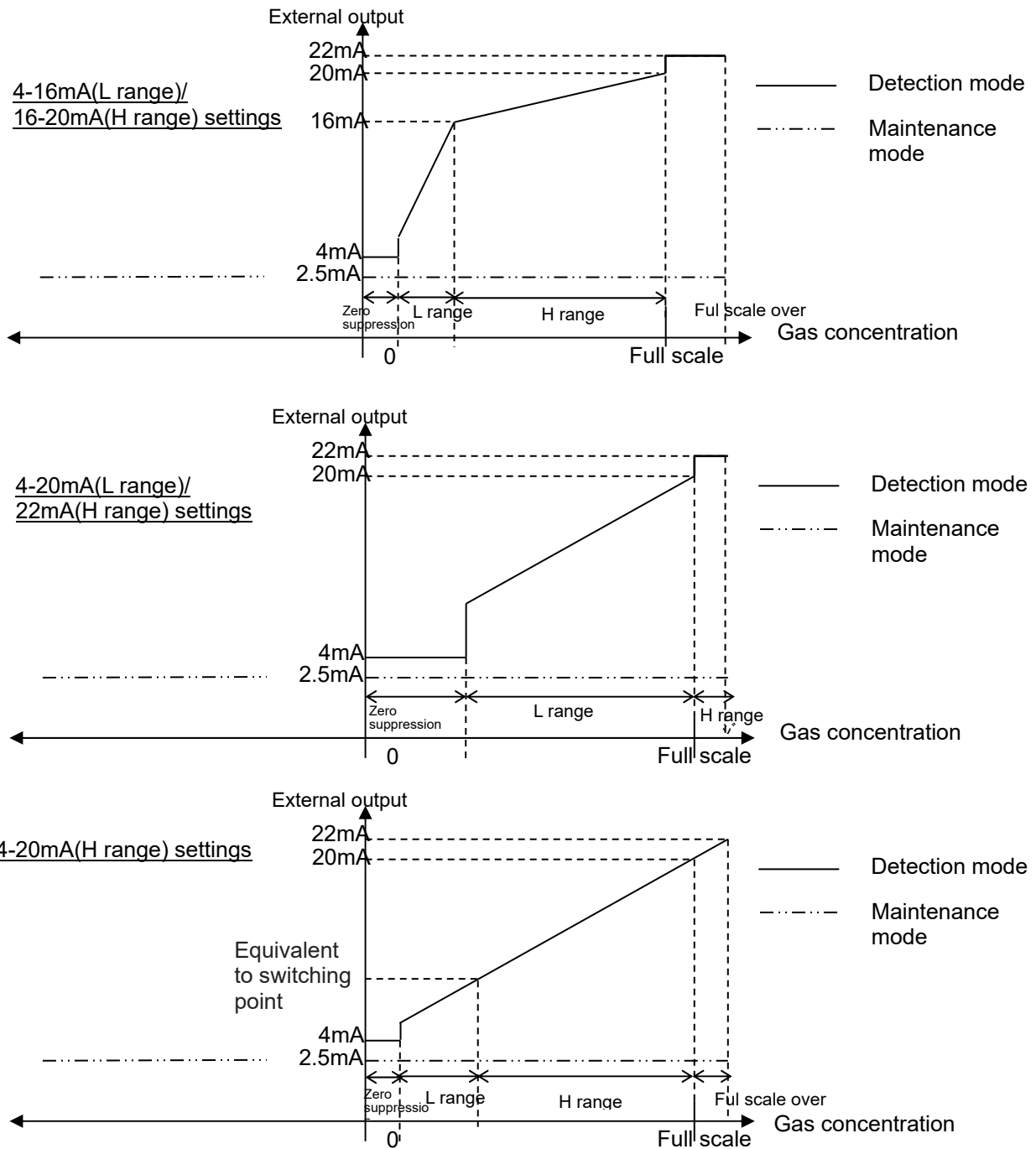

NOTE

SD - D 58 (TYPE NCW) has two indication ranges (L range / H range). When the instructed flammable gas concentration exceeds the full scale of the L range, it automatically switches to the H range.

Also, when the gas concentration falls below the full scale of the L range, it switches to the L range again.

In the case of the L range, **[L range lamp]** lights up and in the case of the H range, **[H range lamp]** lights up, Indicates the current instruction range (L range or H range).

For example,

Gas to be instructed	:	Isobutane	
Instruction range	:	0-10.0%LEL	/ 0-100%LEL
Status display	:	[L] (L range)	/ [H] (H range)

6-5. Other functions

<Suppression Function>

The sensors used with the detector head are influenced by environmental changes (temperature, humidity, and other characteristics) or interference gases (interference characteristics) in no small measure, which affects the reading. Therefore, the reading might be fluctuated around zero even in a normal environment. This function obscures influences by environmental changes and interference gases around zero that have no meaning for your management rules of gas alarm. This function is used to hide (suppress) the fluctuation of the reading under the setting value, indicating zero.

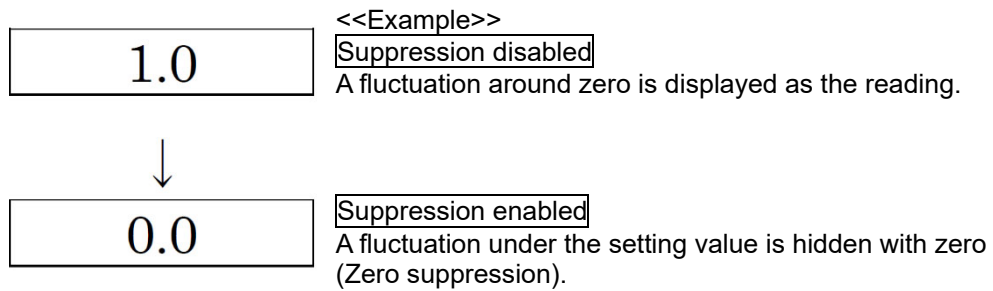

NOTE

- The suppression function is factory-set. The standard setting value is TYPE GP/TYP E GP H: 2% FS and TYPE NC/TYP E NC H/TYP E NCW: 10% FS.
- In the maintenance mode, this function is disabled and the fluctuation of the reading under the setting value is displayed.



CAUTION

- A reading under zero is suppressed with the 10% FS suppression.
- A reading that gets 10% FS or more under zero is displayed as "-0.0", which prevents an accurate gas detection and needs the zero adjustment.

7

Maintenance

The detector head is an important instrument for the purpose of safety. To maintain the performance of the detector head and improve the reliability of safety, perform a regular maintenance.

7-1. Maintenance intervals and items

- Daily maintenance: Perform maintenance before beginning to work.
- Monthly maintenance: Perform maintenance on the alarm circuit (alarm test) once a month.
- Regular maintenance: Perform maintenance once or more for every six months to maintain the performance as a safety unit.

Maintenance item	Maintenance content	Daily maintenance	Monthly maintenance	Regular maintenance
Power supply check	Check that the power lamp lights up.	○	○	○
Concentration display check	Check that the concentration display value is zero. When the reading is incorrect, perform the zero adjustment after ensuring that no other gases exist around it.	○	○	○
Alarm test	Check the alarm circuit by using the alarm test function.	—	○	○
Span adjustment	Perform the sensitivity calibration by using the calibration gas.	—	—	○
Gas alarm check	Check the gas alarm by using the calibration gas.	—	—	○
Flow sensor check	Check the flow sensor by using the test pump.	—	—	○

<About Maintenance Services>

- We provide services on regular maintenance including span adjustment, other adjustments and maintenance.
To make the calibration gas, dedicated tools, such as a gas cylinder of the specified concentration and gas sampling bag must be used.
Our qualified service engineers have expertise and knowledge on the dedicated tools used for services, along with other products. To maintain the safety operation of the detector head, please use our maintenance service.

- The followings are typical maintenance services. For more information, please contact RIKEN KEIKI.

Main services

- Power supply check : Checks the power supply voltage.
Verifies that the power lamp lights up.
(Verifies that relevant points can be identified on the system.)
(When a UPS (uninterruptible power system) is used, checks the operation with the UPS.)
- Concentration display check : Verifies that the concentration display value is zero by using the zero gas.
Performs the zero adjustment (fresh air adjustment) if the reading is incorrect.
- Flow rate check : Checks the flow rate indicator to find abnormalities.
Checks the flow rate by using an external flow meter to verify the correctness of the flow rate indicator on the device. If the flow rate is incorrect, performs the flow rate adjustment.
- Filter check : Checks the dust filter for dust or clogging.
Replaces a dirty or clogged dust filter.
- Alarm test : Inspects the alarm circuit by using the alarm test function.
 - Checks the alarm lamps. (Checks activation.)
 - Checks the external alarm. (Checks the activation of the external alarm, such as a buzzer.)
- Span adjustment : Performs the span adjustment by using the calibration gas.
- Gas alarm check : Checks the gas alarm by using the calibration gas.
 - Checks the alarm. (Checks the alarm activation when the alarm setpoint is reached)
 - Checks the delay time. (Checks time to delay until the alarm is triggered.)
 - Checks the alarm lamps. (Checks activation.)
 - Checks the external alarm. (Checks the activation of external alarms, such as a buzzer and reset signal.)
- Cleaning and repair of device (visual diagnosis) : Checks dust or damage on surface, cover, or internal parts of the detector head, cleans and repairs such parts of the device.
Replaces parts which are cracked or damaged.
- Device operation check : Uses the keys to check the operation of functions and parameters.
- Replacement of consumable parts : Replaces consumable parts, such as a sensor, filter and pump.

7-2. Maintenance mode (Regular maintenance)



WARNING

After the adjustment is completed, never fail to press MENU/ESC key to return to the detection mode.
(If the detector head remains in the maintenance mode, it automatically returns to the detection mode in ten hours.)

Mode	Item	LED display	Details
Maintenance mode (Regular maintenance)	Test mode	2-0	Performs various tests. 2-0.0 Gas test 2-0.1 Alarm test 2-0.2 Fault test 2-0.3 LED test 2-0.4 Memory test
	Zero adjustment	2-1	Performs the zero adjustment.
	Span adjustment	2-2	Performs the span adjustment.
	Zero/span initialization	2-3	Initializes zero/span values.
	Environmental setting	2-4	Used for various environmental settings. 2-4.0 Heater voltage adjustment 2-4.1 INHIBIT setting 2-4.2 Alarm setpoint setting 2-4.3 Alarm delay time setting 2-4.4 Alarm pattern setting 2-4.5 Zero suppression pattern setting 2-4.6 Zero suppression value setting 2-4.7 Alarm contact specification setting 2-4.8 Energized/de-energized contact setting 2-4.9 Zero follower selection 2-4.A Maintenance mode external output setting 2-4.B External output setting 2-4.C Alarm test external output setting 2-4.D Sensor operation start setting 2-4.E Password setting 2-4.F Sensor fault alarm pattern setting 2-4.U Double range external output setting*
	Electrical setting display	2-5	Displays various electrical settings. This is not typically used by the user.
	Flow sensor setting	2-6	2-6.0 Flow sensor heater voltage adjustment 2-6.1 Flow rate zero point setting 2-6.2 Low flow rate threshold value setting 2-6.3 Flow sensor zero point check 2-6.4 Flow sensor output check 2-6.5 Pump output check 2-6.6 Flow sensor initialization 2-6.7 Flow sensor operation start setting 2-6.8 Low flow rate alarm delay time setting 2-6.9 Flow sensor function ON/OFF setting
	Flow sensor various setting display	2-7	Displays various settings of the flow sensor. This is not typically used by the user.
	Switches to factory mode	2-8	Not used.
	Switches to user mode	2-9	Returns to the user mode.

* There is "2-4.U Double range external output setting" only for TYPE NCW.

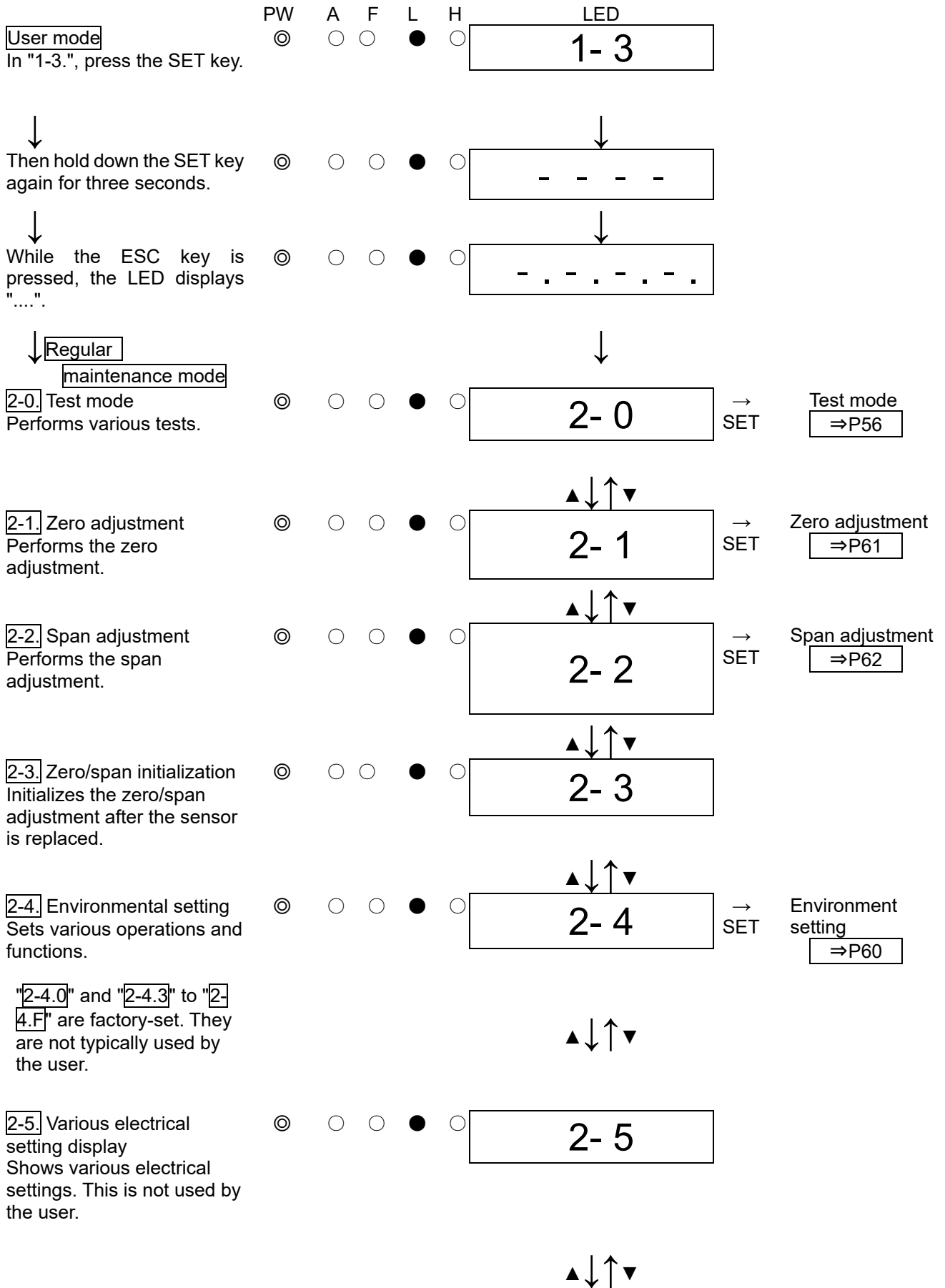

* Only for TYPE NCW There are L range lamp and H range lamp.

2-6. Flow sensor setting 2- 6 → SET ⇒P65 Flow sensor setting
 Sets the flow sensor functions.

"2-6.0," "2-6.5" to "2-6.6," and "2-6.8" to "2-6.9" are factory-set. They are not typically used by the user.



2-7. Flow sensor setting display 2- 7
 Displays settings of the flow sensor. This is not used by the user.



2-8. 2- 8
 Enters the factory mode. This is not used by the user.



2-9. 2- 9 → SET

rET. is displayed. Press the SET key again to return to the user mode.



To **2-0.** Test mode

* Only for TYPE NCW There are L range lamp and H range lamp

<Test Mode "2-0">

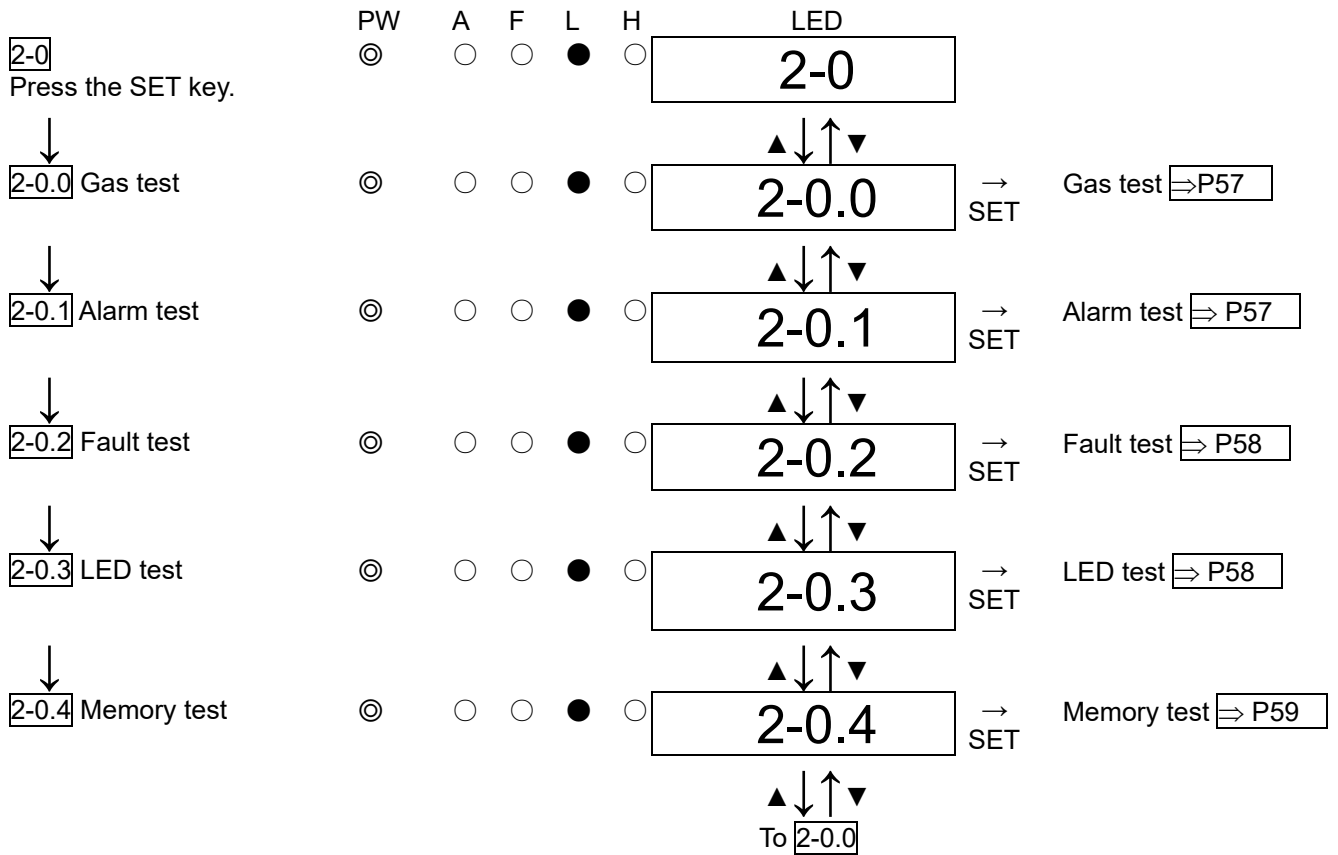

* Only for TYPE NCW There are L range lamp and H range lamp.



WARNING

- Before starting the alarm test (transmission test), provide a notification to the related sections so that they can prepare for false abnormalities (external output signals and alarm contact). After the test is completed, never fail to press the MENU/ESC key to return to the detection mode. (If the detector head remains in the alarm test mode, it automatically returns to the detection mode in ten hours.)
- In the alarm test mode, the gas concentration equal to the reading is output even in the maintenance mode depending on the setting. Take actions, if necessary, so that the signal receiver side can prepare to avoid false alarms.

<Fault Test "2-0.2">

2-0.2

Press the SET key.



Fault test ON/OFF

Select either ON/OFF.

Switch ON and press the SET key to trigger the fault alarm.

Return to OFF and press the SET key to cancel the test.

(Pressing the MENU/ESC key also enables to cancel the test and to go back to the original state.)

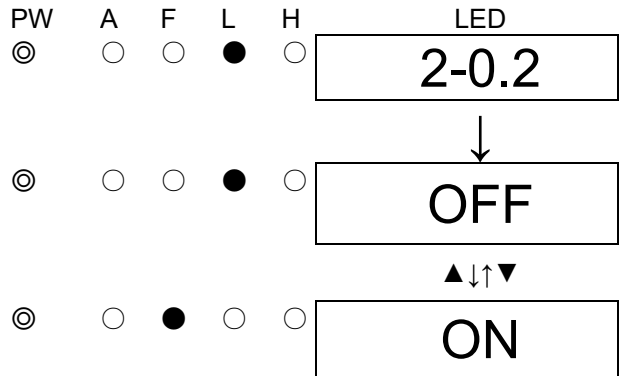

* Only for TYPE NCW There are L range lamp and H range lamp.



WARNING

Because the contact and gas concentration output can be activated by a fault test even in the maintenance mode depending on setting, be careful to perform the test.

<LED Test "2-0.3">

2-0.3

Press the SET key.



LED test ON/OFF

Select either ON/OFF.

Switch ON and press the SET key to turn on the LEDs (POWER, ALM, FAULT) and to display the gas concentration of 8.8.8.8.

Return to OFF and press the SET key to cancel the test.

(Pressing the MENU/ESC key also enables to cancel the test and to go back to the original state.)

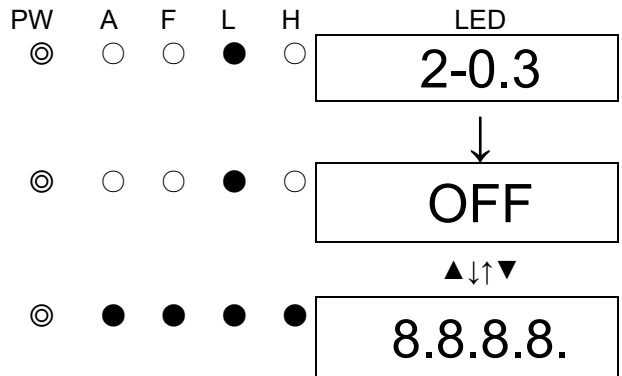

* Only for TYPE NCW There are L range lamp and H range lamp.

<Memory Test "2-0.4">

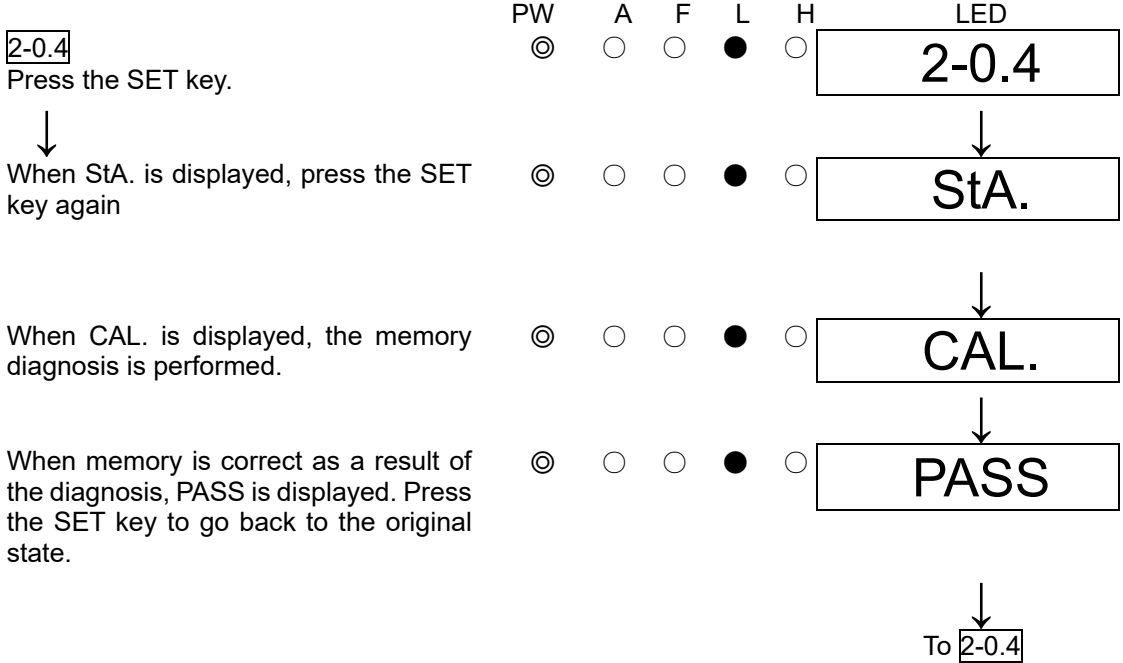

* Only for TYPE NCW There are L range lamp and H range lamp.

NOTE

When abnormalities are found in memory as a result of the diagnosis, PASS is not displayed. F-RA is displayed for the RAM fault, and F-RO is displayed for the ROM fault. For both the RAM fault and ROM fault, F-RA and F-RO are displayed alternately.

<Environmental Setting "2-4">

Set various operations and functions in the environmental setting.

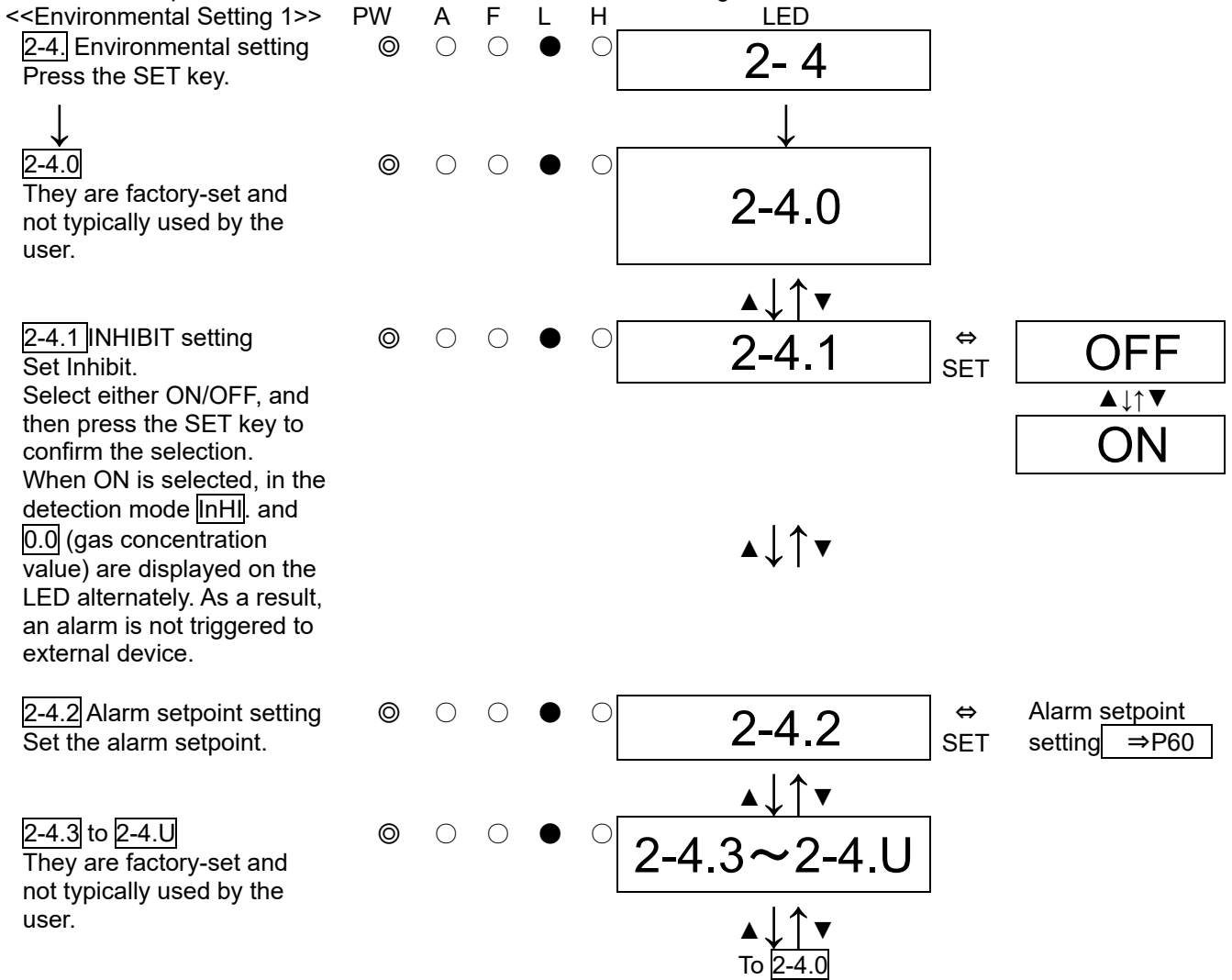

* Only for TYPE NCW There are L range lamp and H range lamp.
* There is "2-4.U double range external output setting" only for TYPE NCW.

<Alarm Setpoint Setting "2-4.2">

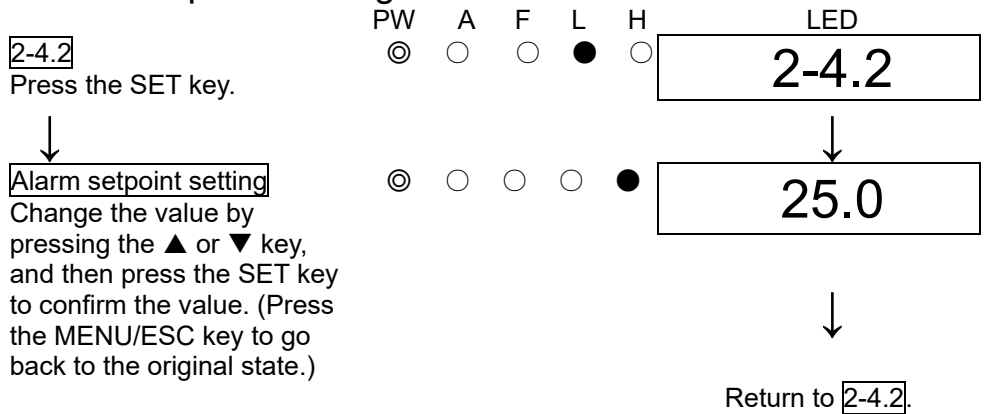

* Only for TYPE NCW There are L range lamp and H range lamp.

NOTE

A value exceeding 60% LEL cannot be set.

7-3. Gas calibration method

Perform a gas calibration in each mode (zero adjustment mode and span adjustment mode) using the calibration gas.

- Zero adjustment gas
- Span adjustment gas (collected in a gas sampling bag)
- Gas sampling bags

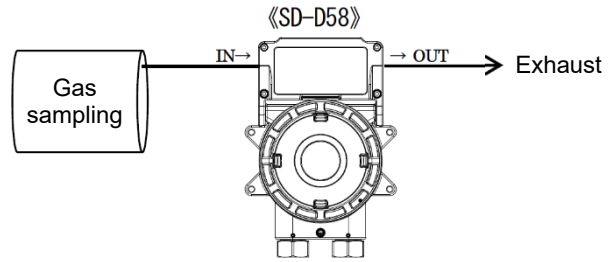

<Zero Adjustment "2-1">

This is used to perform the zero adjustment.

WARNING

When the zero adjustment is performed in the atmosphere, check the atmosphere for freshness before beginning the adjustment. If other gases exist, the adjustment cannot be performed properly, thus leading to dangers when the gas leaks.

NOTE

Before starting the zero adjustment, provide the detector head with the zero adjustment gas and wait until the indicator is stabilized.

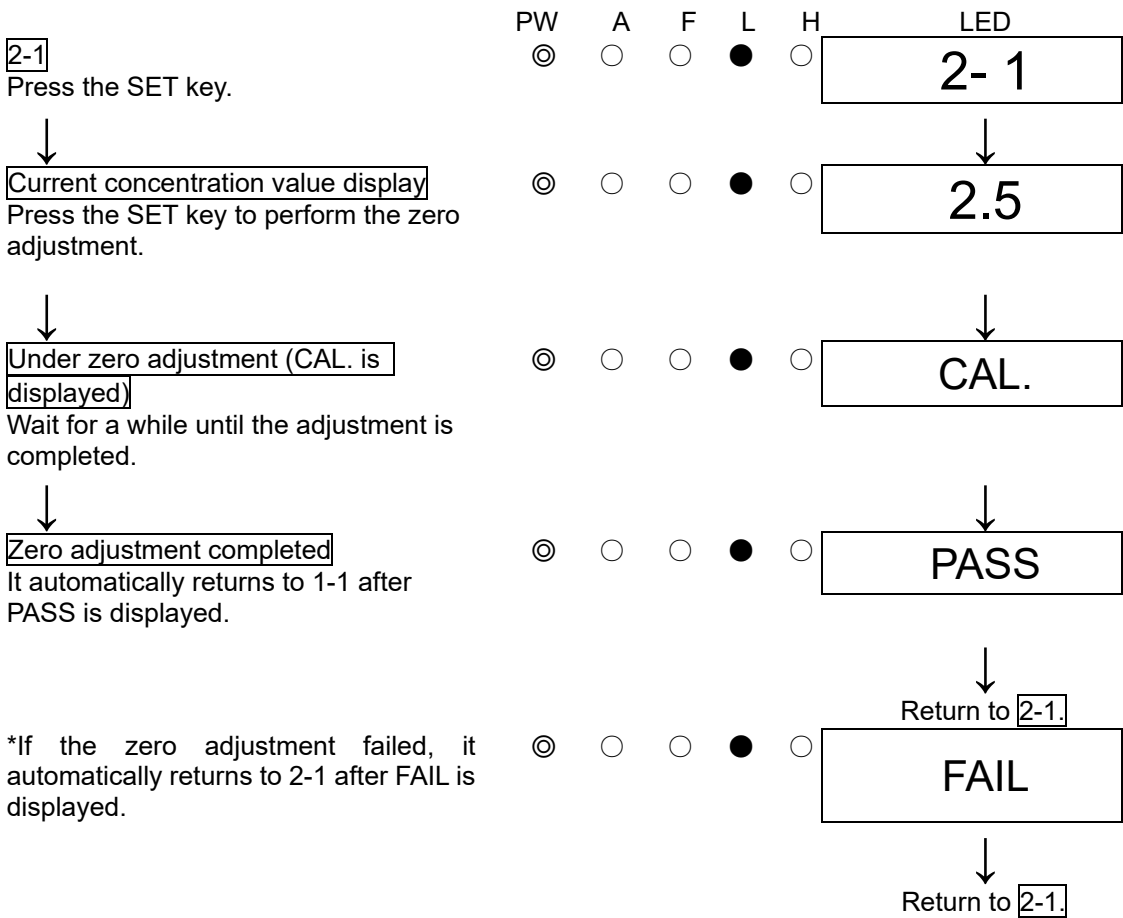

* Only for TYPE NCW There are L range lamp and H range lamp.

NOTE

If the zero calibration failed since the zero point was significantly fluctuated from around zero, it returns to 2-1 after FAIL rather than PASS is displayed. In this case, the zero adjustment has not been completed.

This is used to perform the span adjustment.



CAUTION

Before starting the span adjustment, provide the detector head with the span adjustment gas and wait until the indicator is stabilized.

In cases other than TYPE NCW

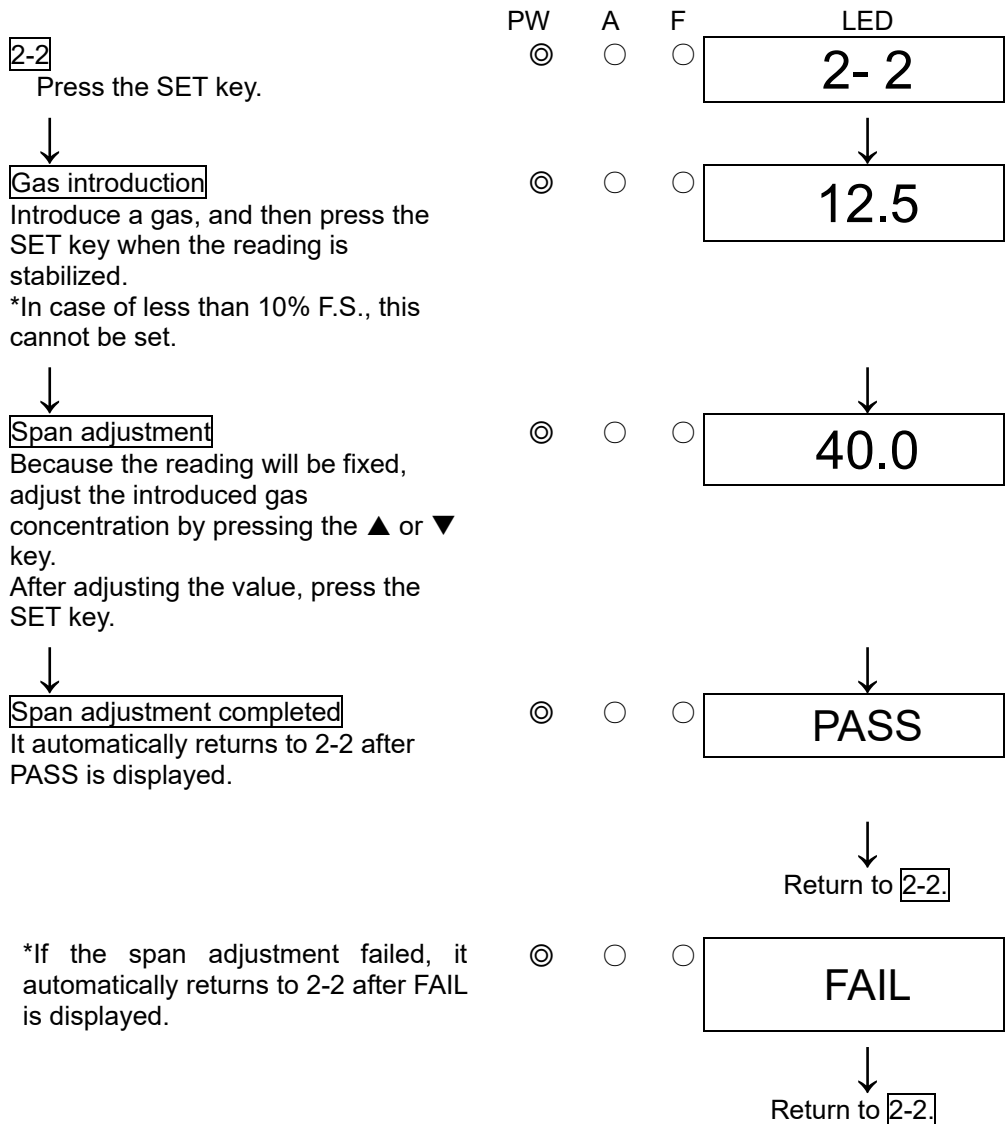

In cases TYPE NCW

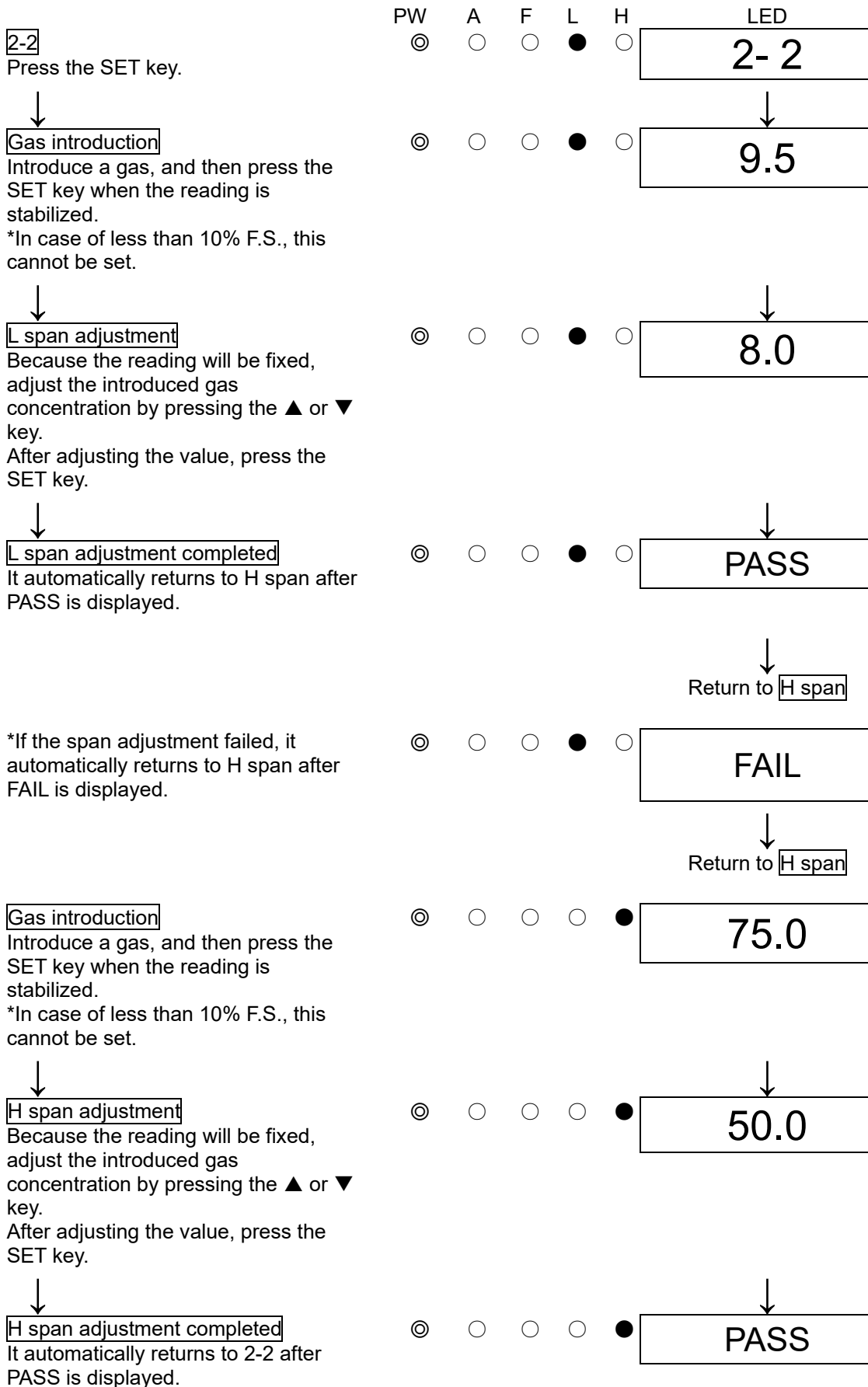

*If the span adjustment failed, it automatically returns to 2-2. after FAIL is displayed.

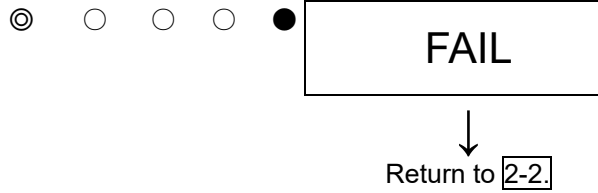

* Only for TYPE NCW There are L range lamp and H range lamp.

NOTE

- If the span adjustment failed since the reading was significantly fluctuated from the introduced gas concentration, it returns to 2-2 after FAIL rather than PASS is displayed . In this case, the span adjustment has not been completed.
Check if the correct concentration span adjustment gas has been provided and check the gas adjustment tool for a gas leak. If there are mistakes, perform the span adjustment again.
- If the span adjustment cannot be performed even when there is no mistake or after the correction, the gas sensor life has expired. After turning off the power supply, please contact RIKEN KEIKI.

<Flow Sensor Setting "2-6">

Flow rate zero adjustment "2-6.1"

This is used to perform the zero adjustment on the flow sensor.



CAUTION

- Before starting the zero adjustment of the flow sensor, remove the pump and wait until the flow sensor output is stabilized.

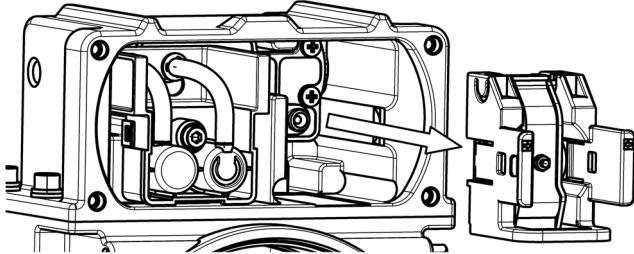

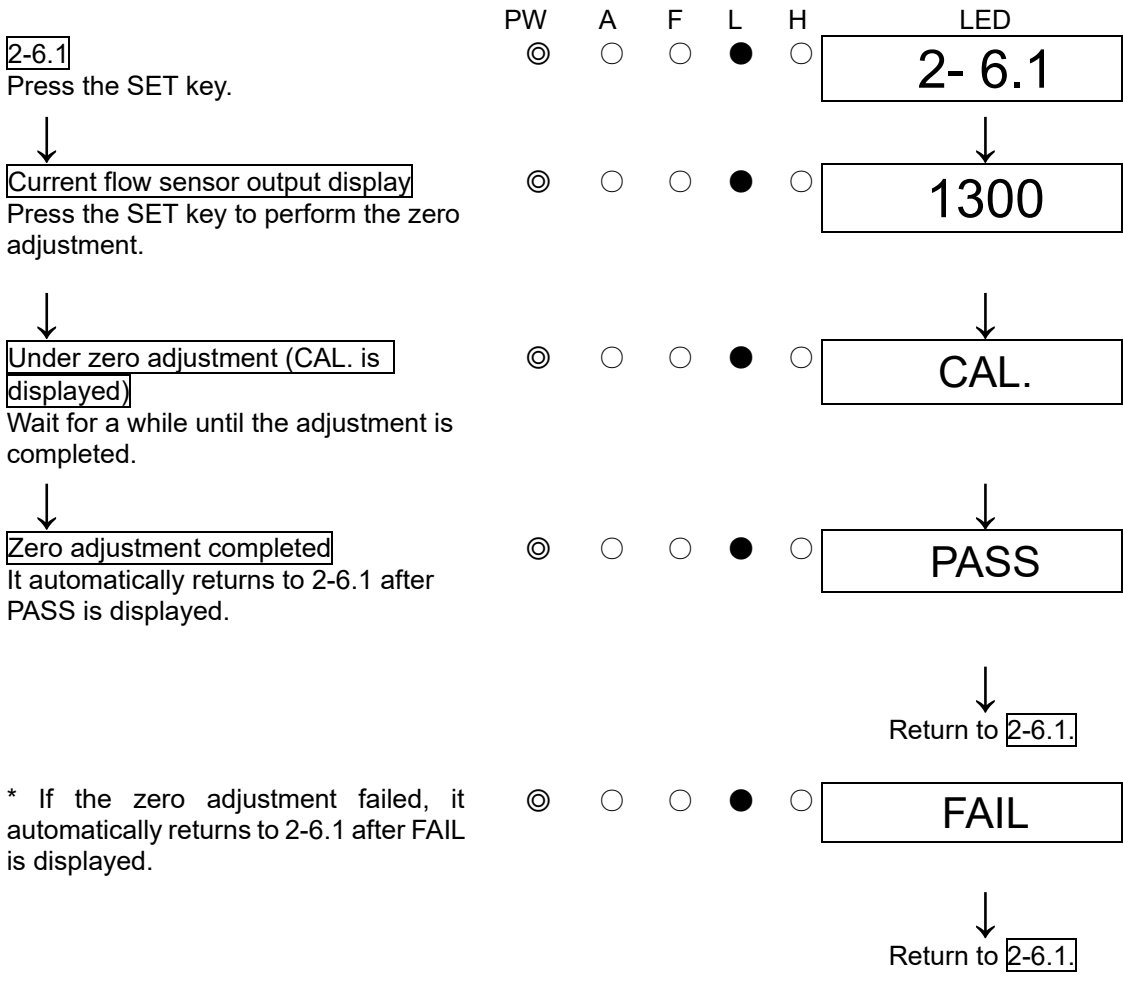

* Only for TYPE NCW There are L range lamp and H range lamp.

<Low Flow Rate Threshold Value Setting "2-6.2">

This is used to set the threshold value for low flow rate.



CAUTION

Set the threshold value for low flow rate to one of the symbols ("a" to "e") printed on the flow sensor.
If any other setting is used the low flow rate function may not operate correctly

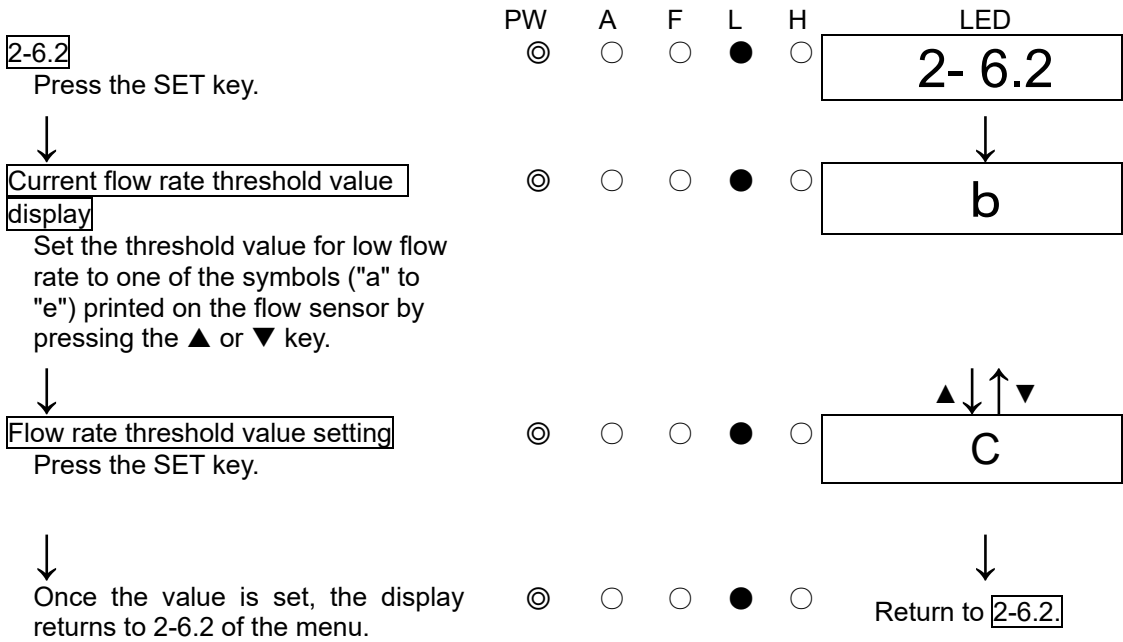

* Only for TYPE NCW There are L range lamp and H range lamp.

<Flow Sensor Operation Start Setting "2-6.7">

This is used to set the flow sensor operation start.

CAUTION

- Make this setting only once at the operation start of the flow sensor.
- Make this setting after conducting the flow rate zero adjustment and setting the threshold value.

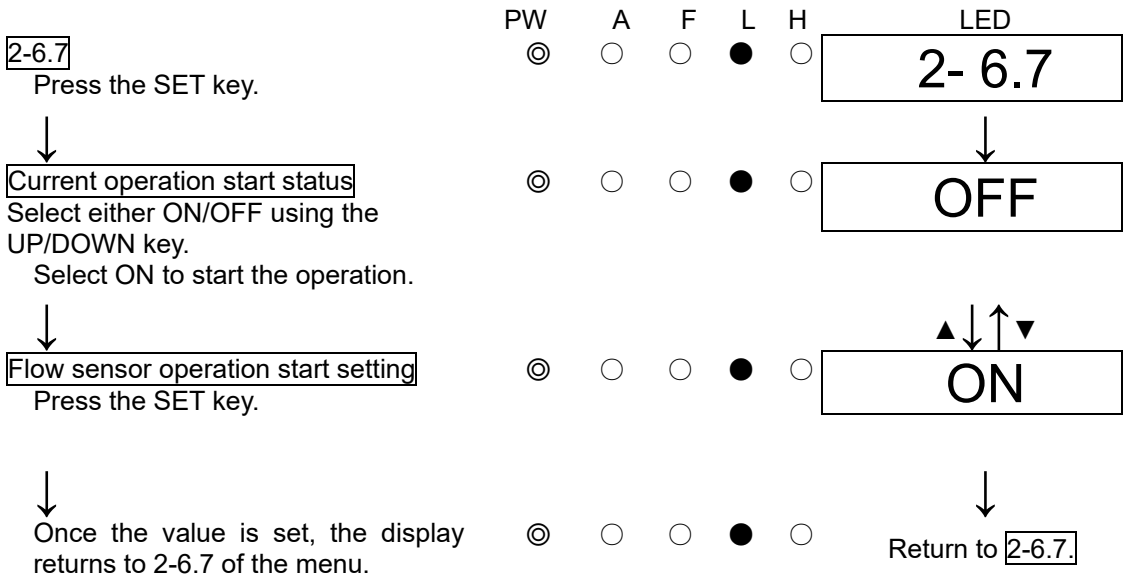

* Only for TYPE NCW There are L range lamp and H range lamp.

7-4. How to maintain flow sensor

Remove the pump.



2-6.3 Flow sensor zero point check
Press the SET key.

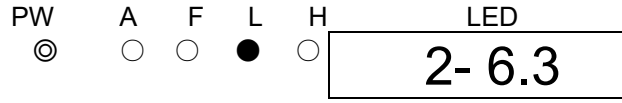

Flow sensor zero point check completed

It automatically returns to 2-6.3 after PASS is displayed.

* If the zero point check of the flow sensor fails, it automatically returns to 2-6.3 after FAIL is displayed.

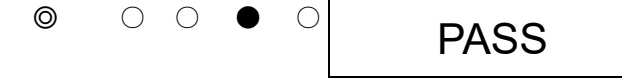

Return to **2-6.3**.



Install the test pump.



2-6.4 Flow sensor output check
Check the flow sensor output during the pump operation.

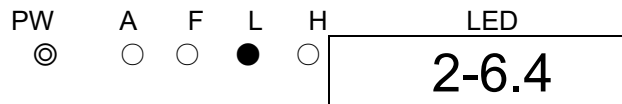

Flow sensor output check completed

It automatically returns to 2-6.4 after PASS is displayed.

* If the output check of the flow sensor failed, it automatically returns to 2-6.4 after FAIL is displayed.

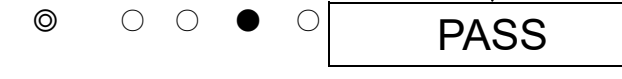

Return to **2-6.4**.

* Only for TYPE NCW There are L range lamp and H range lamp.

7-5. Parts replacement

<Gas Sensor Replacement>

To replace the gas sensor, use the following procedure.

1. Turn off the power supply.
2. Open the cover of the drive unit and remove the sensor cap. (Use a hexagonal wrench (nominal 4).

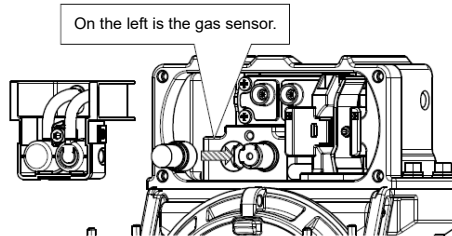

3. Remove the sensor and insert the new sensor. Insert the sensor with the longest pin facing right.

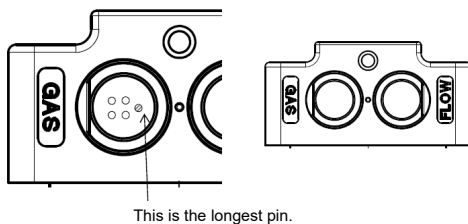

4. After installing the sensor, attach the sensor cap and tighten the hexagon socket bolt.

< Flow Sensor Replacement>

To replace the flow sensor, use the following procedure.

1. Turn off the power supply.
2. Open the cover of the drive unit and remove the sensor cap. (Use a hexagonal wrench (nominal 4).

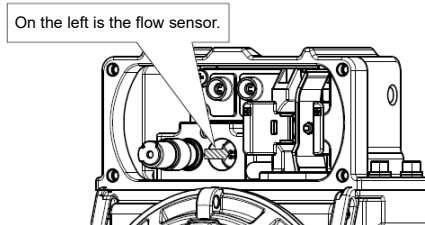

3. Remove the sensor and insert the new sensor. Insert the sensor with the longest pin facing right. Record the symbols (A, b, c, d, and E) printed on the sensor to be replaced.

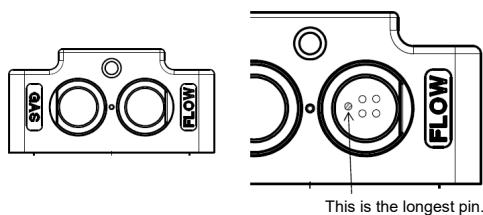

4. After installing the sensor, attach the sensor cap and tighten the hexagon socket bolt.

NOTE

The gas calibration using the standard gas is required after the sensor is replaced. The zero adjustment is required after the flow sensor is replaced. Please make a request to RIKEN KEIKI.

<Replacement of Regular Replacement Parts>

List of recommended regular replacement parts

Name	Maintenance intervals	Replacement intervals (year)	Quantity (pieces/unit)	Remarks
AC/DC converter (Only SD-D58·AC)	6 months	3 - 6 years	1	※
Flow sensor	6 months	2 years	1	※
Tubes	6 months	3 - 8 years	1	※
Pump unit	6 months	1 - 2 years	1	※
Chamber assembly	6 months	3 - 8 years	1	※
Sensor cap assembly	6 months	3 - 8 years	1	※

※After the part is replaced, the operation must be checked by a qualified service engineer.

For the stable operation of the detector and safety, ask a qualified service engineer to take care of replacement of the parts whose operation must be checked. Please contact our sales department.

NOTE

The above replacement intervals are recommendation only. The intervals may change depending on the conditions such as the operating environment. These intervals do not mean the warranty periods either. The result of the regular maintenance may determine when to replace the parts.

8

Storage, Relocation and Disposal

8-1. Procedures to store the detector head or leave it for a long time

The detector must be stored under the following environmental conditions.

- In a dark place under the normal temperature and humidity away from direct sunlight
- In a place where gases, solvents or vapors are not present

8-2. Procedures to relocate the detector head or use it again

When the detector head is relocated, select a new place in accordance with "4-2. Precautions for installation points" and "4-4. How to install".

For information on wiring, see "4-5. How to wire". The unpowered time must be minimized when the detector head is relocated.



CAUTION

When using a relocated or stopped/stored detector head again, never fail to perform a gas calibration. For information on readjustment including a gas calibration, please contact RIKEN KEIKI.

8-3. Product disposal

Dispose of the product as industrial waste (incombustible) in accordance with local regulations.

<Disposal in EU member states>

- Waste Electrical and Electronic Equipment (WEEE) directive



The symbol on the product shown on the left indicates that the product and its individual parts must not be disposed of with general or household waste, and must be sorted and disposed of appropriately.

Proper disposal will help prevent potential negative effects on human health and the environment.

To ensure proper treatment, collection, and recycling of the product at the time of its disposal, please use the return and collection system available in your country. For more information on collecting and recycling used products, please contact the dealer or supplier from whom you purchased the product.

9

Troubleshooting

The Troubleshooting does not explain the causes of all the malfunctions which occur on the detector head. This simply helps to find the causes of malfunctions which frequently occur. If the detector head shows a symptom which is not explained in this manual, or still has malfunctions even though remedial actions are taken, please contact RIKEN KEIKI.

<Abnormalities on Unit>

Symptom/Display	FAULT	Causes	Actions
<u>The power cannot be turned on.</u>	—	The wiring is not correct.	Connect the wiring properly.
		The terminal plate is removed.	Connect the terminal plate properly.
		Abnormalities/momentary blackout of power supply system	Provide the rated voltage. Take measures such as checking or adding the UPS, power supply line filter and insulation transformer.
		Cable abnormalities (open circuit/not connected/short circuit)	Check the wiring of detector head and related devices around it.
<u>Abnormal operations</u>	—	Disturbances by sudden surge noise, etc.	Turn off and restart the detector head. If such a symptom is observed frequently, take appropriate measures to eliminate the noise.
<u>Sensor abnormalities</u> E-1	●	The sensor is not connected or improperly connected.	Check if the cable is securely fastened to the terminal plate.
		Zero drift caused by environmental changes or aging deterioration becomes out of the range of zero follower.	Perform the zero adjustment. If the symptom persists after the zero adjustment, replace the sensor with a new one.
		Faults of the sensor	Replace the sensor with a new one.
<u>Low flow rate abnormality</u> E-5	●	The flow rate is low.	The possible causes are deterioration or clogging of the pump or clogging of the tube. Check the flow rate.
		Faults of the flow sensor	Replace the sensor with a new one.
<u>System abnormalities</u> E-9	●	Abnormalities of ROM, RAM, or EEPROM inside of the detector head	Please contact RIKEN KEIKI.

<Abnormalities of Readings>

Symptoms	Causes	Actions
<u>The reading rises (drops) and it remains so.</u>	Drifting of sensor output	Perform the zero adjustment.
	Presence of interference gas	Disturbances by interference gases, such as solvents, cannot be eliminated completely. For information on actions, such as removal filter, please contact RIKEN KEIKI.
	Slow leak	A very small amount of the gas to be detected may be leaking (slow leak). Because ignoring it may cause dangers, take a remedial measure, i.e., taking actions the same as those for the gas alarm.
	Environmental changes	Perform the zero adjustment (AIR adjustment).
<u>A gas alarm is triggered despite of no gas leak and no other abnormalities at the detection point.</u>	Presence of interference gas	Disturbances by interference gases, such as solvents, cannot be eliminated completely. For information on actions, such as removal filter, please contact RIKEN KEIKI.
	Disturbance by noise	Turn off and restart the detector head. If such a symptom is observed frequently, take appropriate measures to eliminate the noise.
	Sudden change in the environment	When the environment (temperature, etc.) changes suddenly, the detector head cannot adjust to it and is affected by it. In some cases, the detector head triggers an indication alarm. Because the detector head cannot be used under sudden and frequent environmental changes, you must take any preventive actions to eliminate them.
<u>Slow response</u>	Deteriorated sensor sensitivity	Replace the sensor with a new one.
<u>Span adjustment impossible</u>	Improper calibration gas concentration	Use the proper calibration gas.
	Sensor sensitivity deterioration	Replace the sensor with a new one.

10

Product Specifications

10-1. List of specifications

[SD-D58·DC(TYPE GP)/ SD-D58·DC(TYPE NC)]<ATEX Specifications>

Model	SD-D58·DC	
Type	TYPE GP	TYPE NC
Detection principle	Catalytic combustion type	New ceramic type
Detection gas	Combustible gas	
Display	Seven-segment LED (four-digit)	
Detection range	0 - 100% LEL	Depend on detection gas
Resolution	0.5% LEL	Depend on detection gas
Alarm setpoints	25% LEL [standard setting value]	Depend on detection gas
Detection method	Sample-drawing	
Flow rate	1.0 L/min or more (at maximum suction pressure of 5.0 kPa <gauge pressure>)	
Power display	POWER lamp on (green)	
External output	Gas concentration signal/alarm contact (gas alarm or fault alarm, gas/fault common alarm)	
Alarm accuracy (under the same conditions)	Within $\pm 25\%$ to the alarm setpoint value	
Response time (under the same conditions)	Within 30 seconds after providing the gas 1.6 times the alarm setpoint (excluding delay in the tube)	
Gas alarm type	One-step alarm (H)	
Gas alarm display	ALM lamp on (red)	
Gas alarm pattern	Non latching (Auto-reset)	
Fault alarm/self diagnosis	System abnormalities/sensor abnormalities/low flow rates	
Fault alarm display	FAULT lamp on (yellow)/detail display	
Fault alarm pattern	Non latching (Auto-reset)	
Alarm contact	No-voltage contact 1a, de-energized (energized in response to an alarm) or energized (de-energized in response to an alarm)	
Contact capacity	30 VDC - 0.5 A (resistant load)	
Transmission system	Three-wire analog transmission(in common with power supply<power supply,signal,common>)	
Transmission specifications	4 - 20 mA DC (no-insulation/load resistance under 300 Ω)	
Power/contact/transmission cable	Shielded cable of CVVS, etc. (1.25mm ² or 2.0mm ²) - 3-core (when the contact is not used) Shielded cable of CVVS, etc. (1.25mm ² or 2.0mm ²) - 5-core (when the contact is used)	

Transmission distance	Less than 250m in case of CVVS 1.25mm ² Less than 450m in case of CVVS 2.0mm ²
Functions	Alarm delay/suppression/zero follower
Power supply	24 VDC ± 10%
Power consumption	Maximum 8.7 W
Cable connecting port	Pressure proof packing gland<G3/4> (Compatible cables φ9.0 - φ16.0mm in outer diameter)
Tube connecting port	Rc1/8 (O.Dφ8-1t half-union for Cu tube <Bs> supplied or half-union for SUS tube <SUS>)
Initial clear	About 25 seconds
Operating temperature	-20 ~ +53°C (Non-rapidly-vary)
Operating humidity	Below 95% RH (Non-condensing)
Structure	Wall mounting type (2B<50A> pipe installation supported),
Explosion-proof structure	Flame-proof enclosures
Explosion-proof class	II 2 G Ex db h II B+H2 T4 Gb
Protection grade	Equivalent to IP67
Dimension	Approx. 197 (W) x 292 (H) x 140 (D) mm (projection portions excluded)
Weight	Approx. 5.8 kg
Outer color	Munsell 7.5BG5/2

* Specifications subject to changes without notice.

[SD-D58·DC(TYPE GP H)/ SD-D58·DC(TYPE NC H)]<ATEX Specifications>

Model	SD-D58·DC	
Type	TYPE GP H	TYPE NC H
Detection principle	Catalytic combustion type	New ceramic type
Detection gas	Combustible gas	
Display	Seven-segment LED (four-digit)	
Detection range	0 - 100% LEL	Depend on detection gas
Resolution	0.5% LEL	Depend on detection gas
Alarm setpoints	25% LEL [standard setting value]	Depend on detection gas
Detection method	Sample-drawing	
Flow rate	1.0 L/min or more (at maximum suction pressure of 5.0 kPa <gauge pressure>)	
Power display	POWER lamp on (green)	
External output	Gas concentration signal/alarm contact (gas alarm or fault alarm, gas/fault common alarm)	
Alarm accuracy (under the same conditions)	Within $\pm 25\%$ to the alarm setpoint value	
Response time (under the same conditions)	Within 30 seconds after providing the gas 1.6 times the alarm setpoint (excluding delay in the tube)	
Gas alarm type	One-step alarm (H)	
Gas alarm display	ALM lamp on (red)	
Gas alarm pattern	Non latching (Auto-reset)	
Fault alarm/self diagnosis	System abnormalities/sensor abnormalities/low flow rates	
Fault alarm display	FAULT lamp on (yellow)/detail display	
Fault alarm pattern	Non latching (Auto-reset)	
Alarm contact	No-voltage contact 1a, de-energized (energized in response to an alarm) or energized (de-energized in response to an alarm)	
Contact capacity	30 VDC - 0.5 A (resistant load)	
Transmission system	Three-wire analog transmission(in common with power supply<power supply,signal,common>)(HART communication)	
Transmission specifications	4 - 20 mA DC (no-insulation/load resistance under 300 Ω)/ HART7(HART communication)	
Power/contact/transmission cable	Shielded cable of CVVS, etc. (1.25mm ² or 2.0mm ²) - 3-core (when the contact is not used) Shielded cable of CVVS, etc. (1.25mm ² or 2.0mm ²) - 5-core (when the contact is used)	
Transmission distance	Less than 250m in case of CVVS 1.25mm ² Less than 450m in case of CVVS 2.0mm ²	
Functions	Alarm delay/suppression/zero follower	
Power supply	24 VDC $\pm 10\%$	
Power consumption	Maximum 8.7 W	
Cable connecting port	Pressure proof packing gland<G3/4> (Compatible cables $\phi 9.0$ - $\phi 16.0$ mm in outer diameter)	
Tube connecting port	Rc1/8 (O.D $\phi 8$ -1t half-union for Cu tube <Bs> supplied or half-union for SUS tube <SUS>)	
Initial clear	About 25 seconds	
Operating temperature	-20 ~ +53°C (Non-rapidly-vary)	
Operating humidity	Below 95% RH (Non-condensing)	
Structure	Wall mounting type (2B<50A> pipe installation supported)	
Explosion-proof structure	Flame-proof enclosures	

Explosion-proof class	II 2 G Ex db h II B+H2 T4 Gb
Protection grade	Equivalent to IP67
Dimension	Approx. 197 (W) x 292(H) x 140 (D) mm (projection portions excluded)
Weight	Approx. 5.8 kg
Outer color	Munsell 7.5BG5/2

* Specifications subject to changes without notice.

[SD-D58·DC(TYPE NCW)]<ATEX Specifications>

Model	SD-D58·DC
Type	TYPE NCW
Detection principle	New ceramic type
Detection gas	Combustible gas
Display	Seven-segment LED (four-digit)
Detection range	Depend on detection gas
Resolution	Depend on detection gas
Alarm setpoints	Depend on detection gas
Detection method	Sample-drawing
Flow rate	1.0 L/min or more (at maximum suction pressure of 5.0 kPa <gauge pressure>)
Power display	POWER lamp on (green)
External output	Gas concentration signal/alarm contact (gas alarm or fault alarm, gas/fault common alarm)
Alarm accuracy (under the same conditions)	Within $\pm 25\%$ to the alarm setpoint value
Response time (under the same conditions)	Within 30 seconds after providing the gas 1.6 times the alarm setpoint (excluding delay in the tube)
Gas alarm type	One-step alarm (H)
Gas alarm display	ALM lamp on (red)
Gas alarm pattern	Non latching (Auto-reset)
Fault alarm/self diagnosis	System abnormalities/sensor abnormalities/low flow rates
Fault alarm display	FAULT lamp on (yellow)/detail display
Fault alarm pattern	Non latching (Auto-reset)
Alarm contact	No-voltage contact 1a, de-energized (energized in response to an alarm) or energized (de-energized in response to an alarm)
Contact capacity	30 VDC - 0.5 A (resistant load)
Transmission system	Three-wire analog transmission(in common with power supply<power supply,signal,common>)
Transmission specifications	4 - 20mADC (no-insulation/load resistance under 300 Ω) [Standard] 4-16mA (L range) / 16-20mA (H range) [Options] 4-20mA (L range) / 22mA (H range) or 4-20mA (H range)
Power/contact/transmission cable	Shielded cable of CVVS, etc. (1.25mm ² or 2.0mm ²) - 3-core (when the contact is not used) Shielded cable of CVVS, etc. (1.25mm ² or 2.0mm ²) - 5-core (when the contact is used)
Transmission distance	Less than 250m in case of CVVS 1.25mm ² Less than 450m in case of CVVS 2.0mm ²
Functions	Alarm delay/suppression/zero follower
Power supply	24 VDC $\pm 10\%$
Power consumption	Maximum 8.7 W
Cable connecting port	Pressure proof packing gland<G3/4> (Compatible cables $\phi 9.0$ - $\phi 16.0$ mm in outer diameter)
Tube connecting port	Rc1/8 (O.D $\phi 8$ -1t half-union for Cu tube <Bs> supplied or half-union for SUS tube <SUS>)
Initial clear	About 25 seconds
Operating temperature	-20 ~ +53°C (Non-rapidly-vary)
Operating humidity	Below 95% RH (Non-condensing)
Structure	Wall mounting type (2B<50A> pipe installation supported),

Explosion-proof structure	Flame-proof enclosures
Explosion-proof class	II 2 G Ex db h II B+H2 T4 Gb
Protection grade	Equivalent to IP67
Dimension	Approx. 197 (W) x 292 (H) x 140 (D) mm (projection portions excluded)
Weight	Approx. 5.8 kg
Outer color	Munsell 7.5BG5/2

* Specifications subject to changes without notice.

[SD-D58·AC(TYPE GP)/ SD-D58·AC(TYPE NC)]<Taiwan Ex(TS) Specifications >

Model	SD-D58·AC	
Type	TYPE GP	TYPE NC
Detection principle	Catalytic combustion type	New ceramic type
Detection gas	Combustible gas	
Display	Seven-segment LED (four-digit)	
Detection range	0 - 100% LEL	Depend on detection gas
Resolution	0.5% LEL	Depend on detection gas
Alarm setpoints	25% LEL [standard setting value]	Depend on detection gas
Detection method	Sample-drawing	
Flow rate	1.5 L/min or more (at maximum suction pressure of 5.3 kPa <gauge pressure>)	
Power display	POWER lamp on (green)	
External output	Gas concentration signal/alarm contact (gas alarm or fault alarm, gas/fault common alarm)	
Alarm accuracy (under the same conditions)	Within $\pm 25\%$ to the alarm setpoint value	
Response time (under the same conditions)	Within 30 seconds after providing the gas 1.6 times the alarm setpoint (excluding delay in the tube)	
Gas alarm type	One-step alarm (H)	
Gas alarm display	ALM lamp on (red)	
Gas alarm pattern	Non latching (Auto-reset)	
Fault alarm/self diagnosis	System abnormalities/sensor abnormalities/low flow rates	
Fault alarm display	FAULT lamp on (yellow)/detail display	
Fault alarm pattern	Non latching (Auto-reset)	
Alarm contact	No-voltage contact 1a, de-energized (energized in response to an alarm) or energized (de-energized in response to an alarm)	
Contact capacity	250 VAC - 0.5 A/30 VDC - 0.5 A (resistant load)	
Transmission system	Analog transmission	
Transmission specifications	4 - 20 mA DC (no-insulation/load resistance under 300 Ω)	
Transmission cable	Shielded cable of CVVS, etc. (1.25mm ² or 2.0mm ²) - 2-core (when the contact is not used) Shielded cable of CVVS, etc. (1.25mm ² or 2.0mm ²) - 4-core (when the contact is used)	
Transmission distance	Less than 1.0km in case of CVVS 1.25mm ² Less than 2.0km in case of CVVS 2.0mm ²	
Functions	Alarm delay/suppression/zero follower	
Power cable	CVV, etc. (1.25mm ² or 2.0mm ²) - 2-core or 3-core	
Power supply	100 - 110 VAC, 50/60 Hz	
Power consumption	Maximum 13 VA	
Cable connecting port	Pressure proof packing gland<G3/4> (Compatible cables $\phi 9.0$ - $\phi 16.0$ mm in outer diameter)	
Tube connecting port	Rc1/8 (O.D $\phi 8$ -1t half-union for Cu tube <Bs> supplied or half-union for SUS tube <SUS>)	
Initial clear	About 25 seconds	
Operating temperature	-20 ~ +50°C (Non-rapidly-vary)	
Operating humidity	Below 95% RH (Non-condensing)	
Structure	Wall mounting type (2B<50A> pipe installation supported)	
Explosion-proof	Flame-proof enclosures	

structure	
Explosion-proof class	Ex d II B+H2 T4 Gb
Protection grade	Equivalent to IP67
Dimension	Approx. 197 (W) x 292 (H) x 140 (D) mm (projection portions excluded)
Weight	Approx. 5.8 kg
Outer color	Munsell 7.5BG5/2

* Specifications subject to changes without notice.

[SD-D58•DC(TYPE GP)/ SD-D58•DC(TYPE NC)]<Taiwan Ex(TS) Specifications>

Model	SD-D58•DC	
Type	TYPE GP	TYPE NC
Detection principle	Catalytic combustion type	New ceramic type
Detection gas	Combustible gas	
Display	Seven-segment LED (four-digit)	
Detection range	0 - 100% LEL	Depend on detection gas
Resolution	0.5% LEL	Depend on detection gas
Alarm setpoints	25% LEL [standard setting value]	Depend on detection gas
Detection method	Sample-drawing	
Flow rate	1.0 L/min or more (at maximum suction pressure of 5.0 kPa <gauge pressure>)	
Power display	POWER lamp on (green)	
External output	Gas concentration signal/alarm contact (gas alarm or fault alarm, gas/fault common alarm)	
Alarm accuracy (under the same conditions)	Within $\pm 25\%$ to the alarm setpoint value	
Response time (under the same conditions)	Within 30 seconds after providing the gas 1.6 times the alarm setpoint (excluding delay in the tube)	
Gas alarm type	One-step alarm (H)	
Gas alarm display	ALM lamp on (red)	
Gas alarm pattern	Non latching (Auto-reset)	
Fault alarm/self diagnosis	System abnormalities/sensor abnormalities/low flow rates	
Fault alarm display	FAULT lamp on (yellow)/detail display	
Fault alarm pattern	Non latching (Auto-reset)	
Alarm contact	No-voltage contact 1a, de-energized (energized in response to an alarm) or energized (de-energized in response to an alarm)	
Contact capacity	250 VAC - 0.5 A/30 VDC - 0.5 A (resistant load)	
Transmission system	Three-wire analog transmission(in common with power supply<power supply,signal,common>)	
Transmission specifications	4 - 20 mA DC (no-insulation/load resistance under 300 Ω)	
Power/contact/transmission cable	Shielded cable of CVVS, etc. (1.25mm ² or 2.0mm ²) - 3-core (when the contact is not used) Shielded cable of CVVS, etc. (1.25mm ² or 2.0mm ²) - 5-core (when the contact is used)	
Transmission distance	Less than 250m in case of CVVS 1.25mm ² Less than 450m in case of CVVS 2.0mm ²	
Functions	Alarm delay/suppression/zero follower	
Power supply	24 VDC $\pm 10\%$	
Power consumption	Maximum 8.7 W	
Cable connecting port	Pressure proof packing gland<G3/4> (Compatible cables $\phi 9.0$ - $\phi 16.0$ mm in outer diameter)	
Tube connecting port	Rc1/8 (O.D $\phi 8$ -1t half-union for Cu tube <Bs> supplied or half-union for SUS tube <SUS>)	
Initial clear	About 25 seconds	
Operating temperature	-20 ~ +53°C (Non-rapidly-vary)	
Operating humidity	Below 95% RH (Non-condensing)	
Structure	Wall mounting type (2B<50A> pipe installation supported)	
Explosion-proof structure	Flame-proof enclosures	
Explosion-proof class	Ex d II B+H2 T4 Gb	

Protection grade	Equivalent to IP67
Dimension	Approx. 197 (W) x 292 (H) x 140 (D) mm (projection portions excluded)
Weight	Approx. 5.8 kg
Outer color	Munsell 7.5BG5/2

* Specifications subject to changes without notice.

[SD-D58·AC(TYPE GP)/ SD-D58·AC(TYPE NC)]<Japan Ex Specifications>

Model	SD-D58·AC	
Type	TYPE GP	TYPE NC
Detection principle	Catalytic combustion type	New ceramic type
Detection gas	Combustible gas	
Display	Seven-segment LED (four-digit)	
Detection range	0 - 100% LEL	Depend on detection gas
Display resolution	0.5% LEL	Depend on detection gas
Alarm setpoints	25% LEL [standard setting value]	Depend on detection gas
Detection method	Sample-drawing	
Flow rate	1.5 L/min or more (at maximum suction pressure of 5.3 kPa <gauge pressure>)	
Alarm setpoint value	25% LEL [standard setting value]	
Power display	POWER lamp on (green)	
External output	Gas concentration signal/alarm contact (gas alarm or fault alarm, gas/fault common alarm)	
Alarm accuracy (under the same conditions)	Within $\pm 25\%$ to the alarm setpoint value	
Response time (under the same conditions)	Within 30 seconds after providing the gas 1.6 times the alarm setpoint (excluding delay in the tube)	
Gas alarm type	One-step alarm (H)	
Gas alarm display	ALM lamp on (red)	
Gas alarm pattern	Non latching (Auto-reset)	
Fault alarm/self diagnosis	System abnormalities/sensor abnormalities/low flow rates	
Fault alarm display	FAULT lamp on (yellow)/detail display	
Fault alarm pattern	Non latching (Auto-reset)	
Alarm contact	No-voltage contact 1a, de-energized (energized in response to an alarm) or energized (de-energized in response to an alarm)	
Contact capacity	250 VAC - 0.5 A/30 VDC - 0.5 A (resistant load)	
Transmission system	Analog transmission	
Transmission specifications	4 - 20 mA DC (no-insulation/load resistance under 300 Ω)	
Transmission cable	Shielded cable of CVVS, etc. (1.25mm ² or 2.0mm ²) - 2-core (when the contact is not used) Shielded cable of CVVS, etc. (1.25mm ² or 2.0mm ²) - 4-core (when the contact is used)	
Transmission distance	Less than 1.0km in case of CVVS 1.25mm ² Less than 2.0km in case of CVVS 2.0mm ²	
Functions	Alarm delay/suppression/zero follower	
Power cable	CVV, etc. (1.25mm ² or 2.0mm ²) - 2-core or 3-core	
Power supply	100 - 110 VAC, 50/60 Hz	
Power consumption	Maximum 13 VA	
Cable connecting port	Pressure proof packing gland<G3/4> (Compatible cables $\phi 9.0$ mm - in outer diameter)	
Tube connecting port	Rc1/8 (O.D. $\phi 8$ -1t half-union for Cu tube <Bs> supplied or half-union for SUS tube <SUS>)	
Initial clear	About 25 seconds	
Operating temperature	-20 ~ +50°C (Non-rapidly-vary)	
Operating humidity	Below 95% RH (Non-condensing)	
Structure	Wall mounting type (2B<50A> pipe installation supported)	

Explosion-proof structure	Flame-proof enclosures
Explosion-proof class	Ex d II B+H2 T4
Protection grade	Equivalent to IP67
Dimension	Approx. 197 (W) x 292 (H) x 140 (D) mm (projection portions excluded)
Weight	Approx. 5.8 kg
Outer color	Munsell 7.5BG5/2

* Specifications subject to changes without notice.

[SD-D58·AC(TYPE GP H)/ SD-D58·AC(TYPE NC H)]<Japan Ex Specifications>

Model	SD-D58·AC	
Type	TYPE GP H	TYPE NC H
Detection principle	Catalytic combustion type	New ceramic type
Detection gas	Combustible gas	
Display	Seven-segment LED (four-digit)	
Detection range	0 - 100% LEL	Depend on detection gas
Display resolution	0.5% LEL	Depend on detection gas
Alarm setpoints	25% LEL [standard setting value]	Depend on detection gas
Detection method	Sample-drawing	
Flow rate	1.5 L/min or more (at maximum suction pressure of 5.3 kPa <gauge pressure>)	
Power display	POWER lamp on (green)	
External output	Gas concentration signal/alarm contact (gas alarm or fault alarm, gas/fault common alarm)	
Alarm accuracy (under the same conditions)	Within $\pm 25\%$ to the alarm setpoint value	
Response time (under the same conditions)	Within 30 seconds after providing the gas 1.6 times the alarm setpoint (excluding delay in the tube)	
Gas alarm type	One-step alarm (H)	
Gas alarm display	ALM lamp on (red)	
Gas alarm pattern	Non latching (Auto-reset)	
Fault alarm/self diagnosis	System abnormalities/sensor abnormalities/low flow rates	
Fault alarm display	FAULT lamp on (yellow)/detail display	
Fault alarm pattern	Non latching (Auto-reset)	
Alarm contact	No-voltage contact 1a, de-energized (energized in response to an alarm) or energized (de-energized in response to an alarm)	
Contact capacity	250 VAC - 0.5 A/30 VDC - 0.5 A (resistant load)	
Transmission system	Analog transmission(HART communication)	
Transmission specifications	4 - 20 mA DC (no-insulation/load resistance under 300 Ω)/ HART7(HART communication) .	
Transmission cable	Shielded cable of CVVS, etc. (1.25mm ² or 2.0mm ²) - 2-core (when the contact is not used) Shielded cable of CVVS, etc. (1.25mm ² or 2.0mm ²) - 4-core (when the contact is used)	
Transmission distance	Less than 1.25km in case of CVVS 1.25mm ² Less than 2.0km in case of CVVS 2.0mm ²	
Functions	Alarm delay/suppression/zero follower	
Power cable	CVV, etc. (1.25mm ² or 2.0mm ²) - 2-core or 3-core	
Power supply	100 - 110 VAC, 50/60 Hz	
Power consumption	Maximum 13 VA	
Cable connecting port	Pressure proof packing gland<G3/4> (Compatible cables $\phi 9.0$ mm - in outer diameter)	
Tube connecting port	Rc1/8 (O.D $\phi 8$ -1t half-union for Cu tube <Bs> supplied or half-union for SUS tube <SUS>)	
Initial clear	About 25 seconds	
Operating temperature	-20 ~ +50°C (Non-rapidly-vary)	
Operating humidity	Below 95% RH (Non-condensing)	
Structure	Wall mounting type (2B<50A> pipe installation supported)	

Explosion-proof structure	Flame-proof enclosures
Explosion-proof class	Ex d II B+H2 T4
Protection grade	Equivalent to IP67
Dimension	Approx. 197 (W) x 292 (H) x 140 (D) mm (projection portions excluded)
Weight	Approx. 5.8 kg
Outer color	Munsell 7.5BG5/2

* Specifications subject to changes without notice.

[SD-D58-AC (TYPE NCW)]<Japan Ex Specifications>

Model	SD-D58-AC
Type	TYPE NCW
Detection principle	New ceramic type
Detection gas	Combustible gas
Display	Seven-segment LED (four-digit)
Detection range	Depend on detection gas
Resolution	Depend on detection gas
Detection method	Sample-drawing
Flow rate	1.5 L/min or more (at maximum suction pressure of 5.3 kPa <gauge pressure>)
Alarm setpoints	Depend on detection gas
Power display	POWER lamp on (green)
External output	Gas concentration signal/alarm contact (gas alarm or fault alarm, gas/fault common alarm)
Alarm accuracy (under the same conditions)	Within $\pm 25\%$ to the alarm setpoint value
Response time (under the same conditions)	Within 30 seconds after providing the gas 1.6 times the alarm setpoint (excluding delay in the tube)
Gas alarm type	One-step alarm (H)
Gas alarm display	ALM lamp on (red)
Gas alarm pattern	Non latching (Auto-reset)
Fault alarm/self diagnosis	System abnormalities/sensor abnormalities/low flow rates
Fault alarm display	FAULT lamp on (yellow)/detail display
Fault alarm pattern	Non latching (Auto-reset)
Alarm contact	No-voltage contact 1a, de-energized (energized in response to an alarm) or energized (de-energized in response to an alarm)
Contact capacity	250 VAC - 0.5 A/30 VDC - 0.5 A (resistant load)
Transmission system	Analog transmission
Transmission specifications	4 - 20mADC (no-insulation/load resistance under 300 Ω) [Standard] 4-16mA (L range) / 16-20mA (H range) [Options] 4-20mA (L range) / 22mA (H range) or 4-20mA (H range)
Transmission cable	Shielded cable of CVVS, etc. (1.25mm ² or 2.0mm ²) - 2-core (when the contact is not used) Shielded cable of CVVS, etc. (1.25mm ² or 2.0mm ²) - 4-core (when the contact is used)
Transmission distance	Less than 1.0km in case of CVVS 1.25mm ² Less than 2.0km in case of CVVS 2.0mm ²
Functions	Alarm delay/suppression/zero follower
Power cable	CVV, etc. (1.25mm ² or 2.0mm ²) - 2-core or 3-core
Power supply	100 -110 VAC, 50/60 Hz
Power consumption	Maximum 13 VA
Cable connecting port	Pressure proof packing gland<G3/4> (Compatible cables $\phi 9.0$ mm - in outer diameter)
Tube connecting port	Rc1/8 (O.D $\phi 8$ -1t half-union for Cu tube <Bs> supplied or half-union for SUS tube <SUS>)
Initial clear	About 25 seconds
Operating temperature	-20 ~ +50°C (Non-rapidly-vary)
Operating humidity	Below 95% RH (Non-condensing)
Structure	Wall mounting type (2B<50A> pipe installation supported)

Explosion-proof structure	Flame-proof enclosures
Explosion-proof class	Ex d II B+H2 T4
Protection grade	Equivalent to IP67
Dimension	Approx. 197 (W) x 292 (H) x 140 (D) mm (projection portions excluded)
Weight	Approx. 5.8 kg
Outer color	Munsell 7.5BG5/2

* Specifications subject to changes without notice.

[SD-D58•DC(TYPE GP)/ SD-D58•DC(TYPE NC)]<Japan Ex Specifications>

Model	SD-D58•DC	
Type	TYPE GP	TYPE NC
Detection principle	Catalytic combustion type	New ceramic type
Detection gas	Combustible gas	
Display	Seven-segment LED (four-digit)	
Detection range	0 - 100% LEL	Depend on detection gas
Resolution	0.5% LEL	Depend on detection gas
Alarm setpoints	25% LEL [standard setting value]	Depend on detection gas
Detection method	Sample-drawing	
Flow rate	1.0 L/min or more (at maximum suction pressure of 5.0 kPa <gauge pressure>)	
Power display	POWER lamp on (green)	
External output	Gas concentration signal/alarm contact (gas alarm or fault alarm, gas/fault common alarm)	
Alarm accuracy (under the same conditions)	Within $\pm 25\%$ to the alarm setpoint value	
Response time (under the same conditions)	Within 30 seconds after providing the gas 1.6 times the alarm setpoint (excluding delay in the tube)	
Gas alarm type	One-step alarm (H)	
Gas alarm display	ALM lamp on (red)	
Gas alarm pattern	Non latching (Auto-reset)	
Fault alarm/self diagnosis	System abnormalities/sensor abnormalities/low flow rates	
Fault alarm display	FAULT lamp on (yellow)/detail display	
Fault alarm pattern	Non latching (Auto-reset)	
Alarm contact	No-voltage contact 1a, de-energized (energized in response to an alarm) or energized (de-energized in response to an alarm)	
Contact capacity	250 VAC - 0.5 A/30 VDC - 0.5 A (resistant load)	
Transmission system	Three-wire analog transmission(in common with power supply<power supply,signal,common>)	
Transmission specifications	4 - 20 mA DC (no-insulation/load resistance under 300 Ω)	
Power/contact/transmission cable	Shielded cable of CVVS, etc. (1.25mm ² or 2.0mm ²) - 3-core (when the contact is not used) Shielded cable of CVVS, etc. (1.25mm ² or 2.0mm ²) - 5-core (when the contact is used)	
Transmission distance	Less than 250m in case of CVVS 1.25mm ² Less than 450m in case of CVVS 2.0mm ²	
Functions	Alarm delay/suppression/zero follower	
Power supply	24 VDC $\pm 10\%$	
Power consumption	Maximum 8.7 W	
Cable connecting port	Pressure proof packing gland<G3/4> (Compatible cables $\phi 9.0$ mm - in outer diameter)	
Tube connecting port	Rc1/8 (O.D $\phi 8$ -1t half-union for Cu tube <Bs> supplied or half-union for SUS tube <SUS>)	
Initial clear	About 25 seconds	
Operating temperature	-20 ~ +53°C (Non-rapidly-vary)	
Operating humidity	Below 95% RH (Non-condensing)	
Structure	Wall mounting type (2B<50A> pipe installation supported)	
Explosion-proof structure	Flame-proof enclosures	

Explosion-proof class	Ex d II B+H2 T4
Protection grade	Equivalent to IP67
Dimension	Approx. 197 (W) x 292 (H) x 140 (D) mm (projection portions excluded)
Weight	Approx. 5.8 kg
Outer color	Munsell 7.5BG5/2

* Specifications subject to changes without notice.

[SD-D58•DC(TYPE GP H)/ SD-D58•DC(TYPE NC H)]<Japan Ex Specifications>

Model	SD-D58•DC	
Type	TYPE GP H	TYPE NC H
Detection principle	Catalytic combustion type	New ceramic type
Detection gas	Combustible gas	
Display	Seven-segment LED (four-digit)	
Detection range	0 - 100% LEL	Depend on detection gas
Resolution	0.5% LEL	Depend on detection gas
Alarm setpoints	25% LEL [standard setting value]	Depend on detection gas
Detection method	Sample-drawing	
Flow rate	1.0 L/min or more (at maximum suction pressure of 5.0 kPa <gauge pressure>)	
Power display	POWER lamp on (green)	
External output	Gas concentration signal/alarm contact (gas alarm or fault alarm, gas/fault common alarm)	
Alarm accuracy (under the same conditions)	Within $\pm 25\%$ to the alarm setpoint value	
Response time (under the same conditions)	Within 30 seconds after providing the gas 1.6 times the alarm setpoint (excluding delay in the tube)	
Gas alarm type	One-step alarm (H)	
Gas alarm display	ALM lamp on (red)	
Gas alarm pattern	Non latching (Auto-reset)	
Fault alarm/self diagnosis	System abnormalities/sensor abnormalities/low flow rates	
Fault alarm display	FAULT lamp on (yellow)/detail display	
Fault alarm pattern	Non latching (Auto-reset)	
Alarm contact	No-voltage contact 1a, de-energized (energized in response to an alarm) or energized (de-energized in response to an alarm)	
Contact capacity	250 VAC - 0.5 A/30 VDC - 0.5 A (resistant load)	
Transmission system	Three-wire analog transmission(in common with power supply<power supply,signal,common>)(HART communication)	
Transmission specifications	4 - 20 mA DC (no-insulation/load resistance under 300 Ω)/ HART7(HART communication)	
Power/contact/transmission cable	Shielded cable of CVVS, etc. (1.25mm ² or 2.0mm ²) - 3-core (when the contact is not used) Shielded cable of CVVS, etc. (1.25mm ² or 2.0mm ²) - 5-core (when the contact is used)	
Transmission distance	Less than 250m in case of CVVS 1.25mm ² Less than 450m in case of CVVS 2.0mm ²	
Functions	Alarm delay/suppression/zero follower	
Power supply	24 VDC $\pm 10\%$	
Power consumption	Maximum 8.7 W	
Cable connecting port	Pressure proof packing gland<G3/4> (Compatible cables $\phi 9.0$ mm - in outer diameter)	
Tube connecting port	Rc1/8 (O.D $\phi 8$ -1t half-union for Cu tube <Bs> supplied or half-union for SUS tube <SUS>)	
Initial clear	About 25 seconds	
Operating temperature	-20 ~ +53°C (Non-rapidly-vary)	
Operating humidity	Below 95% RH (Non-condensing)	
Structure	Wall mounting type (2B<50A> pipe installation supported)	
Explosion-proof structure	Flame-proof enclosures	

Explosion-proof class	Ex d II B+H2 T4
Protection grade	Equivalent to IP67
Dimension	Approx. 197 (W) x 292 (H) x 140 (D) mm (projection portions excluded)
Weight	Approx. 5.8 kg
Outer color	Munsell 7.5BG5/2

* Specifications subject to changes without notice.

[SD-D58-DC (TYPE NCW)]<Japan Ex Specifications>

Model	SD-D58-DC
Type	TYPE NCW
Detection principle	New ceramic type
Detection gas	Combustible gas
Display	Seven-segment LED (four-digit)
Detection range	Depend on detection gas
Resolution	Depend on detection gas
Detection method	Sample-drawing
Flow rate	1.0 L/min or more (at maximum suction pressure of 5.0 kPa <gauge pressure>)
Alarm setpoints	Depend on detection gas
Power display	POWER lamp on (green)
External output	Gas concentration signal/alarm contact (gas alarm or fault alarm, gas/fault common alarm)
Alarm accuracy (under the same conditions)	Within $\pm 25\%$ to the alarm setpoint value
Response time (under the same conditions)	Within 30 seconds after providing the gas 1.6 times the alarm setpoint (excluding delay in the tube)
Gas alarm type	One-step alarm (H)
Gas alarm display	ALM lamp on (red)
Gas alarm pattern	Non latching (Auto-reset)
Fault alarm/self diagnosis	System abnormalities/sensor abnormalities/low flow rates
Fault alarm display	FAULT lamp on (yellow)/detail display
Fault alarm pattern	Non latching (Auto-reset)
Alarm contact	No-voltage contact 1a, de-energized (energized in response to an alarm) or energized (de-energized in response to an alarm)
Contact capacity	250 VAC - 0.5 A/30 VDC - 0.5 A (resistant load)
Transmission system	Three-wire analog transmission(in common with power supply<power supply,signal,common>)
Transmission specifications	4 - 20mADC (no-insulation/load resistance under 300 Ω) [Standard] 4-16mA (L range) / 16-20mA (H range) [Options] 4-20mA (L range) / 22mA (H range) or 4-20mA (H range)
Power/contact/transmission cable	Shielded cable of CVVS, etc. (1.25mm ² or 2.0mm ²) - 3-core (when the contact is not used) Shielded cable of CVVS, etc. (1.25mm ² or 2.0mm ²) - 5-core (when the contact is used)
Transmission distance	Less than 250m in case of CVVS 1.25mm ² Less than 450m in case of CVVS 2.0mm ²
Functions	Alarm delay/suppression/zero follower
Power supply	24 VDC $\pm 10\%$
Power consumption	Maximum 8.7W
Cable connecting port	Pressure proof packing gland<G3/4> (Compatible cables $\phi 9.0$ mm - in outer diameter)
Tube connecting port	Rc1/8 (O.D $\phi 8$ -1t half-union for Cu tube <Bs> supplied or half-union for SUS tube <SUS>)
Initial clear	About 25 seconds
Operating temperature	-20 ~ +53°C (Non-rapidly-vary)
Operating humidity	Below 95% RH (Non-condensing)
Structure	Wall mounting type (2B<50A> pipe installation supported)
Explosion-proof structure	Flame-proof enclosures

Explosion-proof class	Ex d II B+H2 T4
Protection grade	Equivalent to IP67
Dimension	Approx. 197 (W) x 292 (H) x 140 (D) mm (projection portions excluded)
Weight	Approx. 5.8 kg
Outer color	Munsell 7.5BG5/2

* Specifications subject to changes without notice.

10-2. Detection principle

[Catalytic Combustion Type]

When a combustible gas burns on the surface of a oxidation catalyst, the catalytic combustion type sensor considers resultant combustion heat as temperature and resistance changes in the platinum wire coil, and measures their gas concentrations.

This sensor detects any combustible gases. The detection range is from zero to the lower explosive limit. When a high-concentrated gas over the lower explosive limit comes into contact with the sensor, it may be a break.

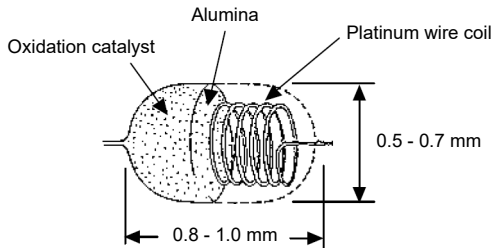

Structure Diagram

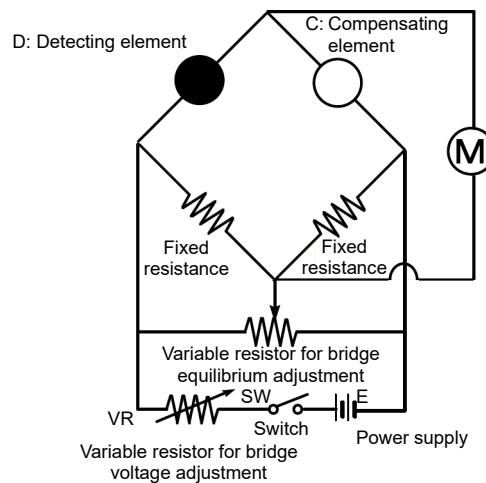

Basic Circuit

[New Ceramic Type]

When a combustible gas burns on the surface of a highly active new ceramic oxidation catalyst in catalytic combustion, the new ceramic-type sensor measures resultant temperature changes by measuring the resistance changes in the heat-resistant alloy wire coil.

The sensor consists of two elements: A detecting element having a heat-resistant alloy wire coil with an ultrafine particle (new ceramic) oxidation catalyst sintered on it together with a carrier and a temperature-compensating element with a mixture of gas-inert alumina and glass sintered on it.

When a combustible gas comes into contact with the surface of the detecting element with new ceramic oxidation catalyst sintered on it, the gas burns, causing the temperature to rise. In accordance with this temperature change, there occurs a change in the resistance of a heat-resistant alloy wire coil that constitutes the element. These resistance values are approximately proportional to gas concentrations. From the changes in the resistance values, potential differences are obtained using a bridge circuit and displayed as gas concentrations on the meter.

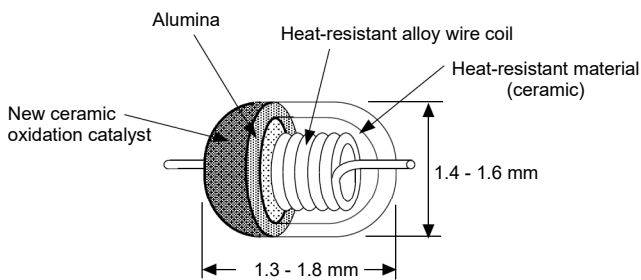

Structure Diagram

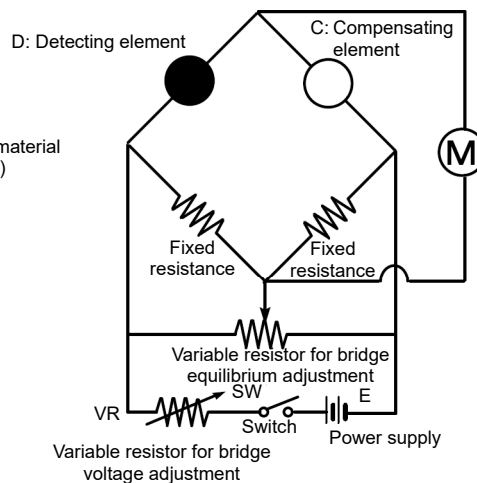

Basic Circuit

[Flow Sensor]

The flow sensor has a circuit that can output a contact signal when the flow rate drops below the preset level.

The flow sensor is a hot-wire type with a Wheatstone bridge consisting of a detecting element, compensating element, and fixed resistance. Contained in a flame arrester container allows it to be flame-proof.

When the drawn air or gas comes into contact with the heated detecting element, the detecting element temperature changes due to the heat dissipation, and the electrical resistance of the element changes according to the temperature changes. Since the resistance changes are in proportion to the gas flow rates, the Wheatstone bridge circuit can identify the changes as the flow rate.

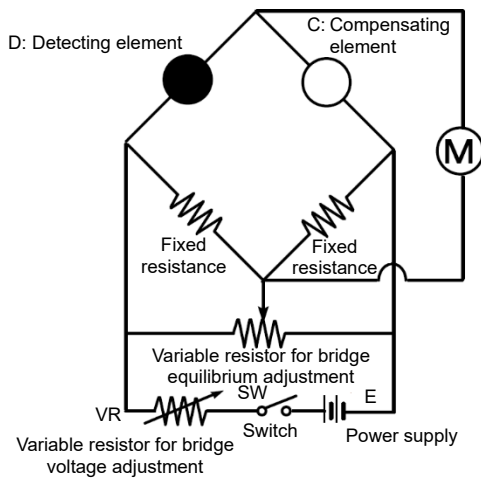

Basic Circuit

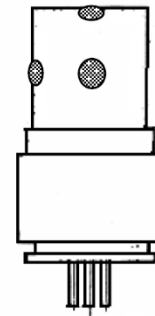

Flow Sensor Appearance

11

Definition of Terms

Catalytic combustion type	This is a principle of the sensor installed in the TYPE GP, TYPE GP H. See "10-2. Detection principle" for details.
New ceramic	This is a principle of the sensor installed in the TYPE NC, TYPE NCW, TYPE NC H. See "10-2. Detection principle" for details.
Initial clear	Output from the detector head fluctuates for a while after turning on the power. This is a function to prevent triggering alarm during that time.
Full scale	Maximum value of the detection range.
%LEL	A unit which the lower explosive limit (LEL) of the combustible gas to be detected is set to 100.
ppm	A concentration unit that means part per million of the combustible gas to be detected.
Calibration	Adjusts the readings to the calibration gas concentration value by using the calibration gas.
Zero suppression	A function to cut off the specific drifting that the sensor has.
Alarm delay time	A function which temporarily suspends activation to prevent a false alarm caused by noise from its outside.
INHIBIT	The gas detection function is temporarily suspended during maintenance, etc. of the detector head. This is also called "point skip", which has the same function.
HART communication	DC4-20mA signal digitals signalling is superimposed, and is methods that transmit multiple signals.